

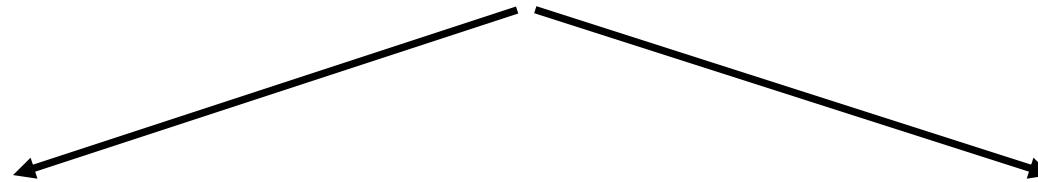



# **MMP Competence Center R&T RoadMap & Competencies**

# *Contribute to the technical and economic competitiveness of metallic solutions in aircrafts, satellites, launchers and turbine engines*



*Support French aerospace industry for **specifications, qualifications and certifications** of innovative metallic materials and processes*

*Accelerate the process for **maturing materials and special processes** for **critical** mechanical systems and structures*



**Targetted industrial applications**

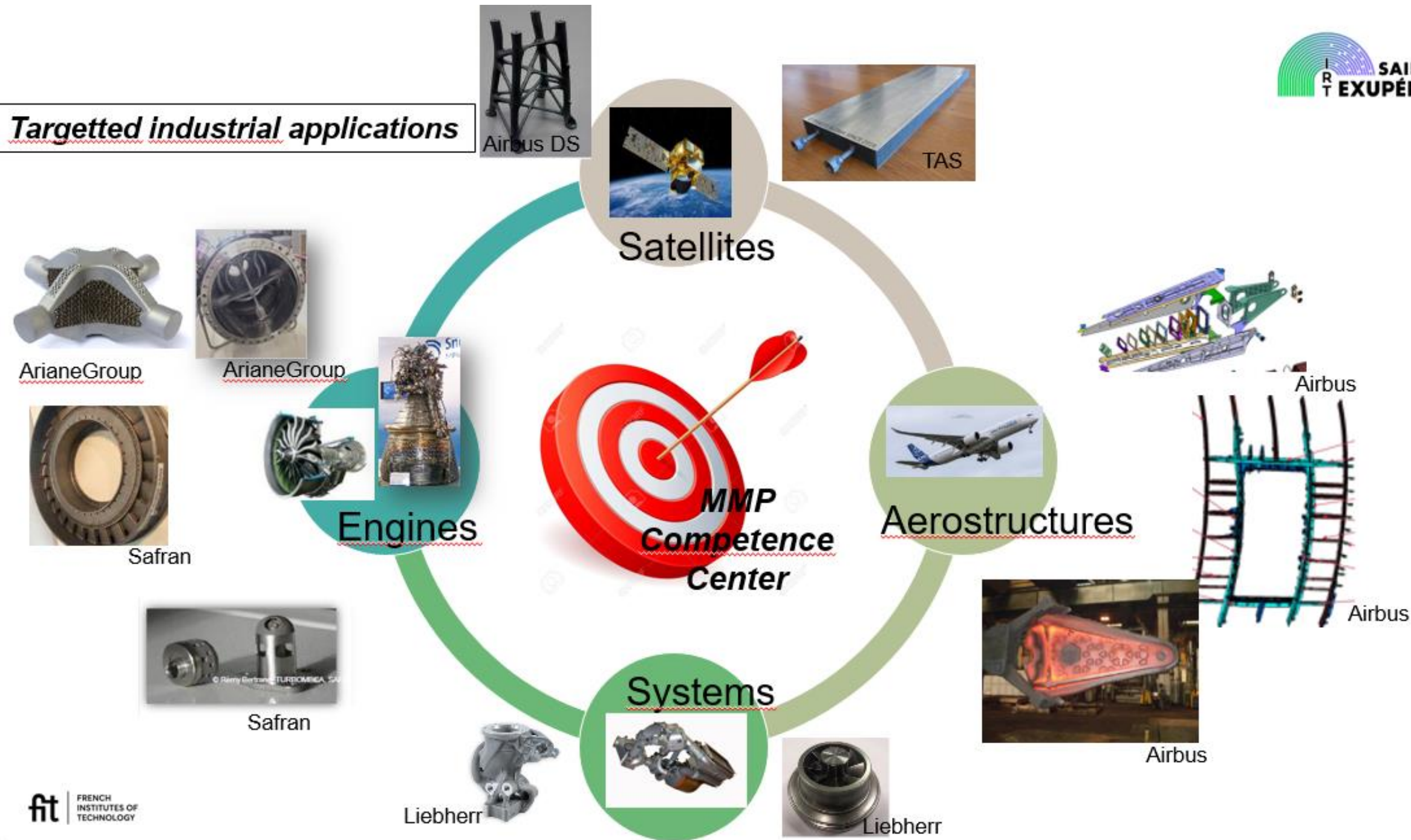

# Road Map MMP (Metallic Materials and Processes) • vision at 5 years.

## Innovative transformation processes

Additive manufacturing, « Net Shape » forging



## Process Hybridization

Additive manufacturing / stamping / forging / repair / functionalization... + associated treatments



2020

## Innovative materials and design

Lattice structures, thin walls, gradient materials, Ni/Ti/Al for AM

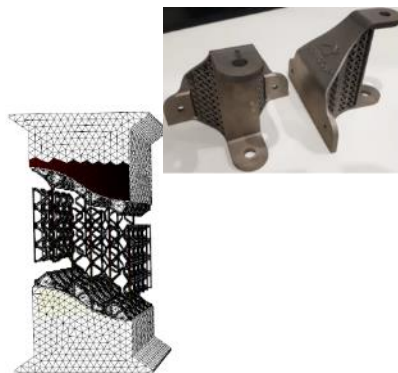

## « Smart » mechanical structures

Multi-functional, microstructures and properties on demand

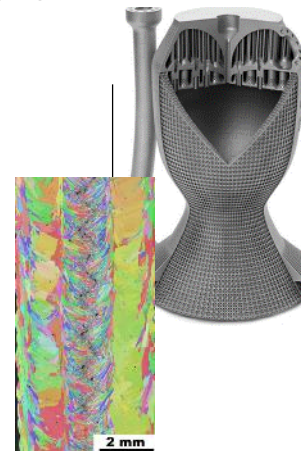

2025

## Materials and structures of the future

Hydrogen propulsion, new generation of turbines and satellites



Eco-Design  
Sobriety  
Sustainability  
Reduction of costs and cycles

### Our competencies:

- Hot transformation processes
- Physical Metallurgy
- Design / mechanical sizing
- Simulation & Modeling

# Road Map MMP (Metallic Materials and Processes) • vision at 5 years.

## Eco-Design

- «Tailor made» materials with specific properties (~~off-the-shelf materials~~)
- Architectural materials combining an optimal choice and distribution of the materials
- Material savings
- Ligthening of structures
- Recycled materials (beginning and end of life)
- Life cycle analysis



*Bone cellular structure*



*Hyperganic Rocket Engine*

## Sobriety

- Weight saving
- Turbomachines efficiency
- Reduction of manufacturing energy consumption

## Sustainability

- Develop durable metallic materials and structures (fatigue, ageing, corrosion issues)
- Address MRO market and develop repair solutions

# Road Map MMP (Metallic Materials and Processes) • vision at 5 years.

## Innovative transformation processes

Additive manufacturing, « Net Shape » forging



## Process Hybridization

Additive manufacturing / stamping / forging / repair / functionalization... + associated treatments



2020

## Innovative materials and design

Lattice structures, thin walls, gradient materials, Ni/Ti/Al for AM

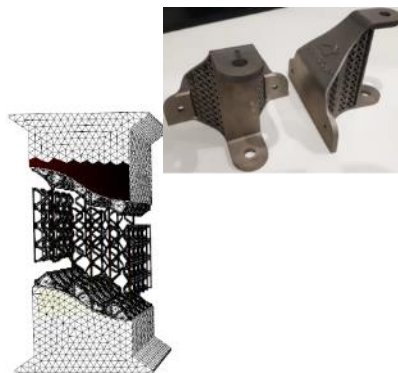

## « Smart » mechanical structures

Multi- functional, on demand microstructures and properties

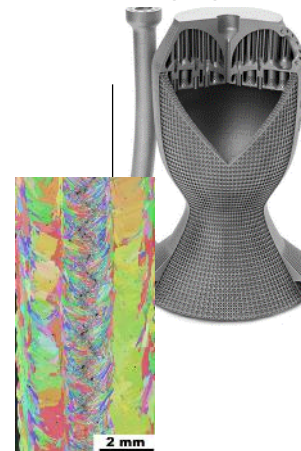

2025

## Materials and structures of the future

Hydrogen propulsion, new generation of turbines and satellites



Eco-Design  
Sobriety  
Sustainability  
Reduction of costs and cycles

### Our competencies:

- Hot transformation processes
- Physical Metallurgy
- Design / mechanical sizing
- Simulation & Modeling

# Our "slogan": Master (micro)structures and mechanical properties for reliable products

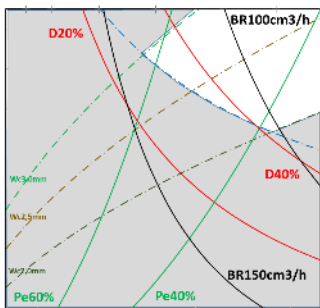

## Materials structures

Multiscale characterization  
Phases transformations  
Defects databases

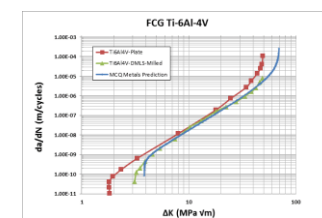
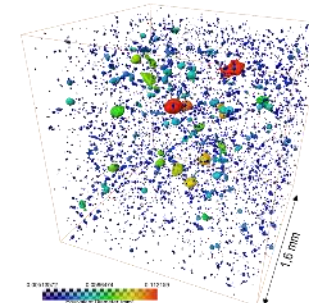
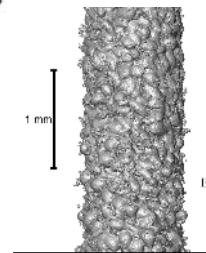
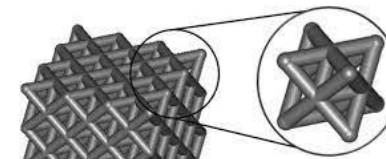
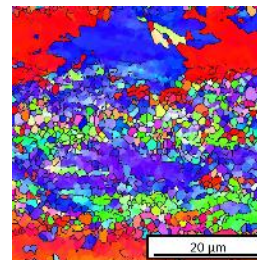

## Processing

Additive Manufacturing  
Net Shape Forging  
AM for repair  
Design to manufacturing  
In-situ monitoring  
Thermal treatments

hybridization

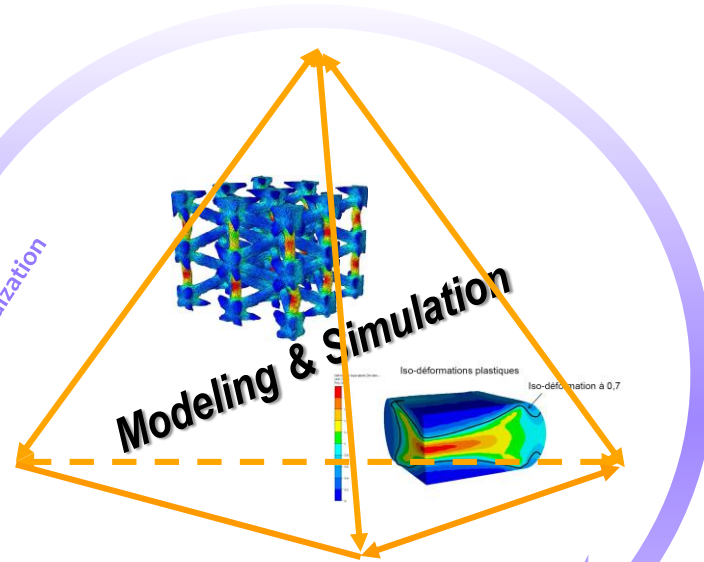

## Properties

Design Allowables: materials & structures  
Fatigue resistance and damage tolerance  
Effect of defects

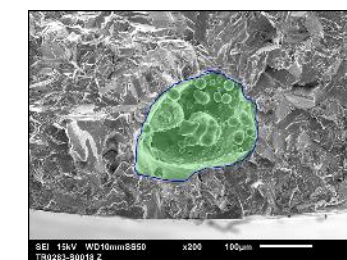

## Performance

Structures in their environment  
Ageing  
Cost

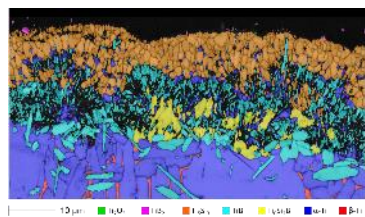

# Our "slogan": Master (micro)structures and mechanical properties for reliable products

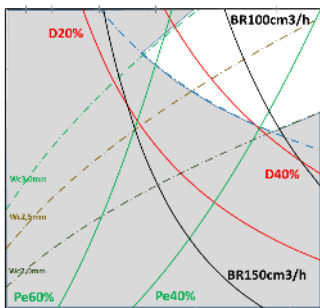

## Materials structures

Multiscale characterization  
Phases transformations  
Defects databases

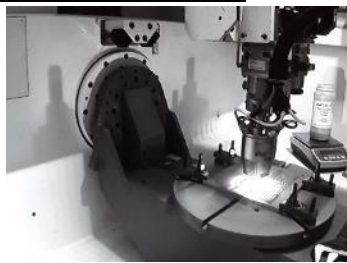
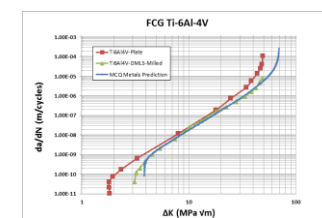
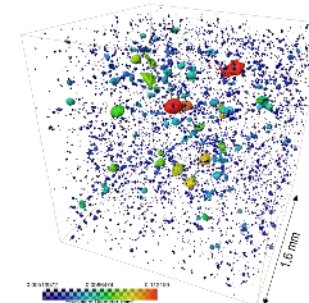
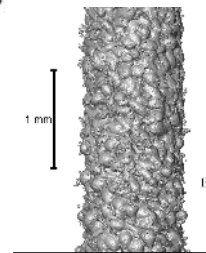
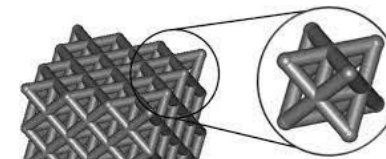
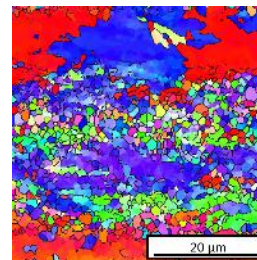

## Processing

Additive Manufacturing  
Net Shape Forging  
AM for repair  
Design to manufacturing  
In-situ monitoring  
Thermal treatments

hybridization

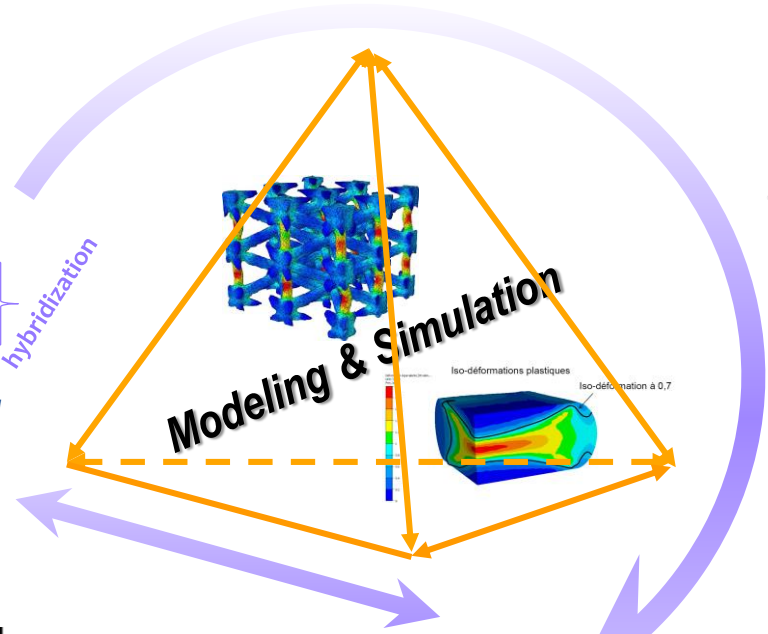

### Modeling & Simulation

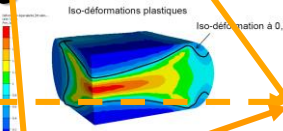

## Properties

Design Allowables: materials & structures  
Fatigue resistance and damage tolerance  
Effect of defects

## Performance

Structures in their environment  
Ageing  
Cost

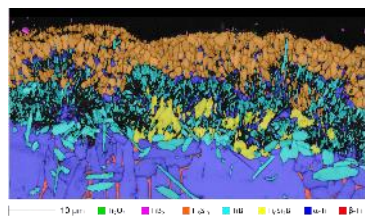
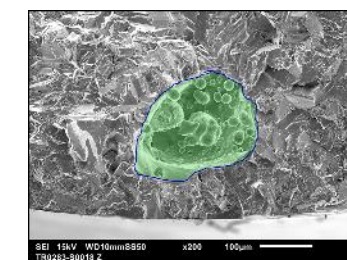
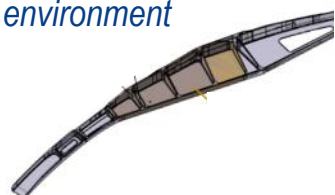

# R&T Deliverables



## Process Aspects

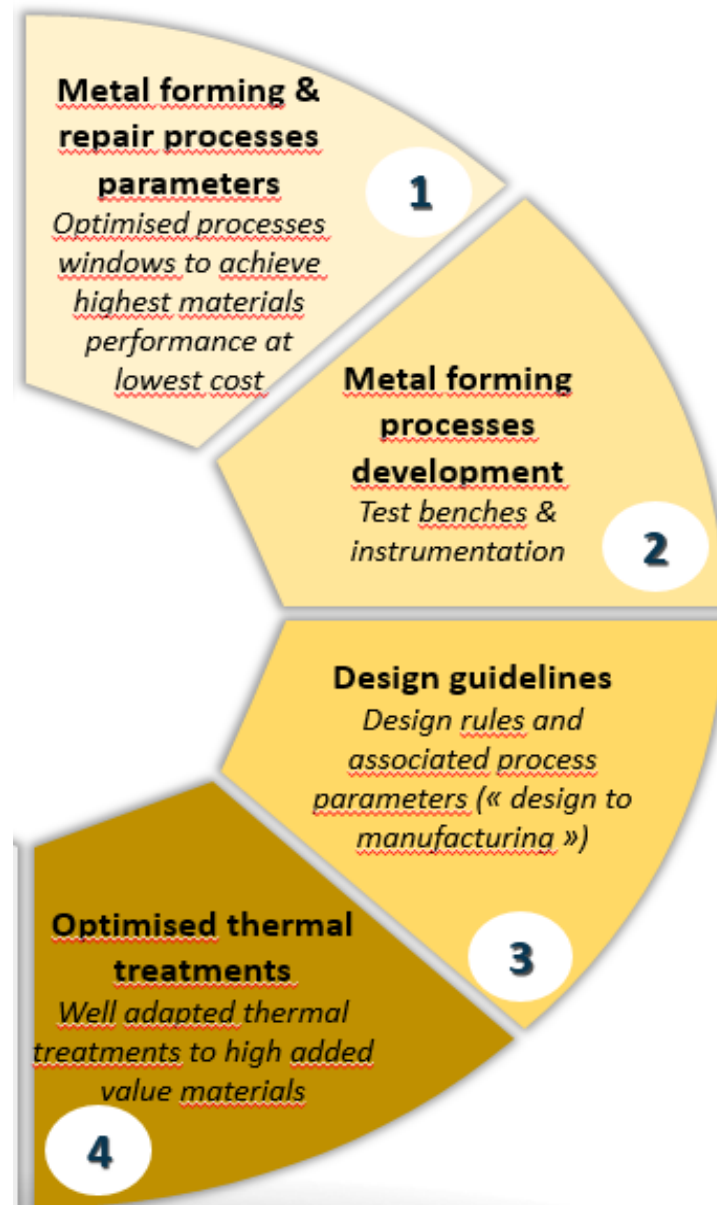

# R&T Deliverables



## Materials Aspects

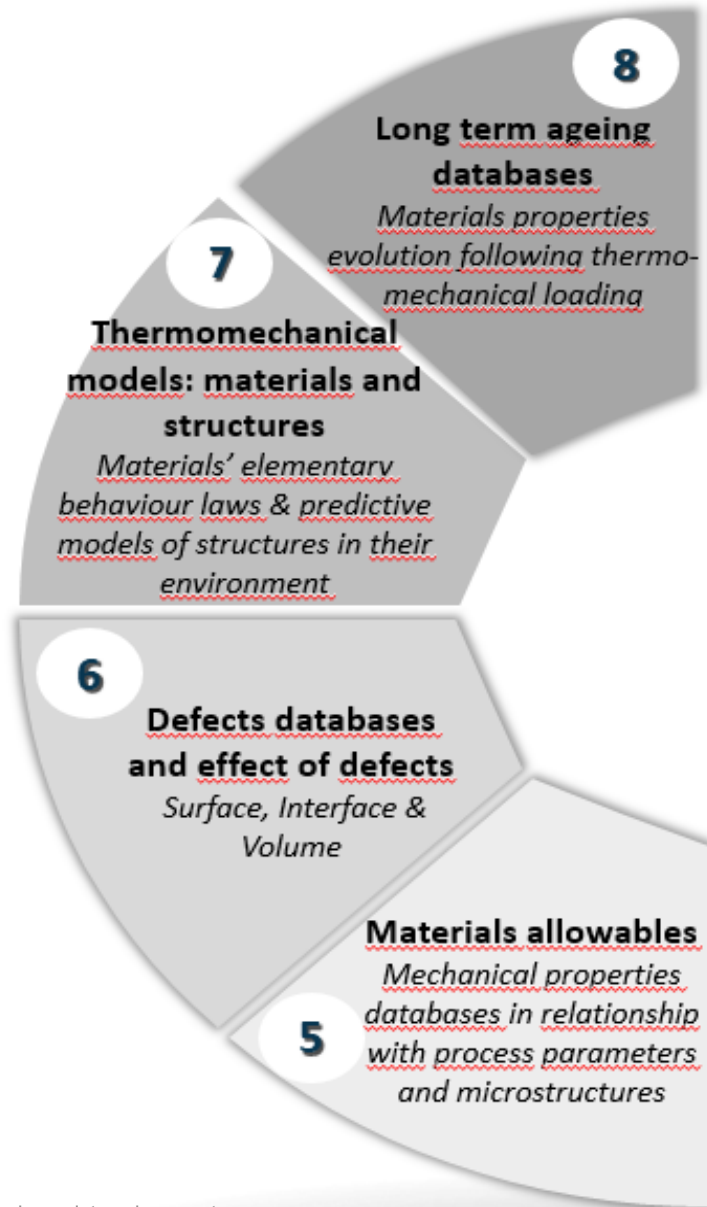





# Human Resources

# Human Resources



HR - CMMP - 06-2021  
HEADCOUNT

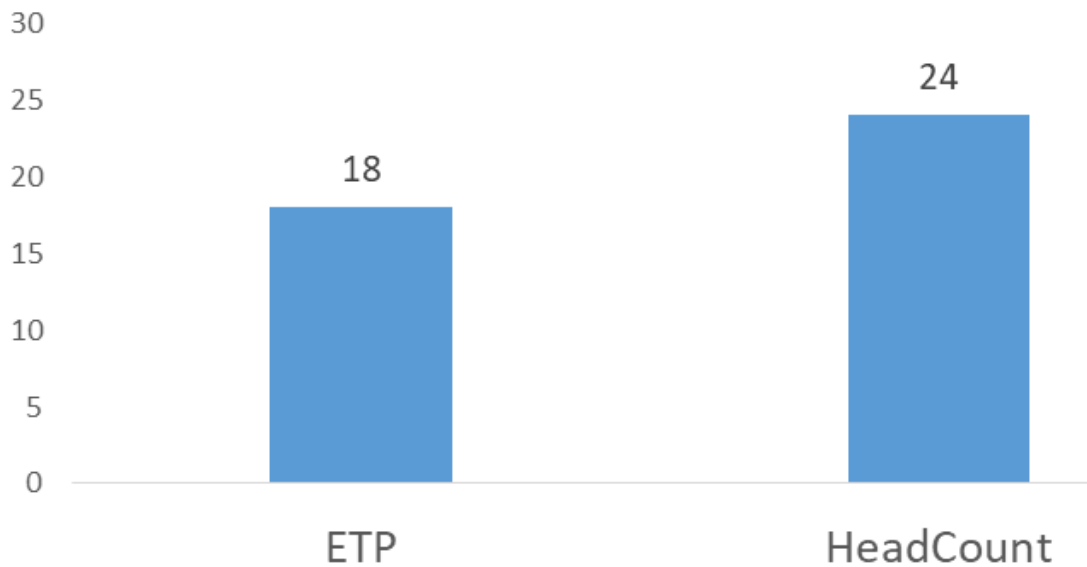

HR - CMMP - 06-2021  
ETP

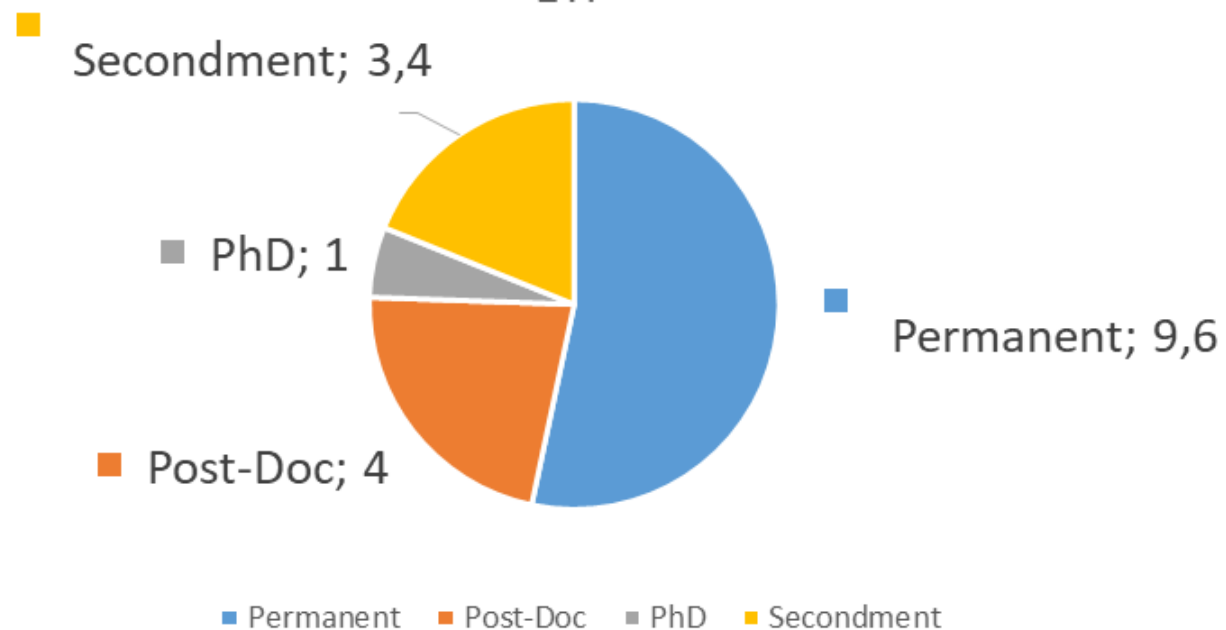

# Human Resources



INTÉRIER

HR - CMMP - 06-2021  
HEADCOUNT

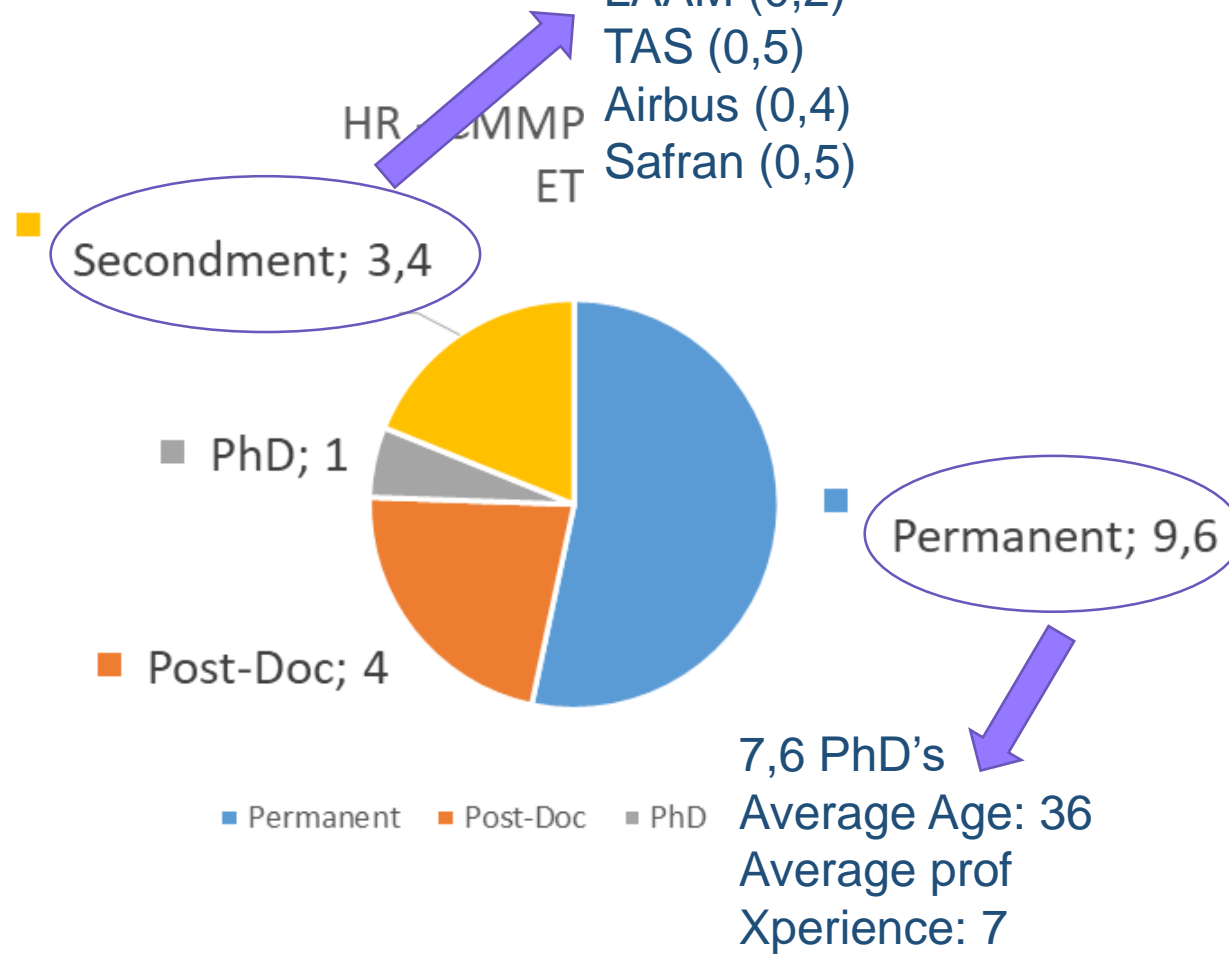
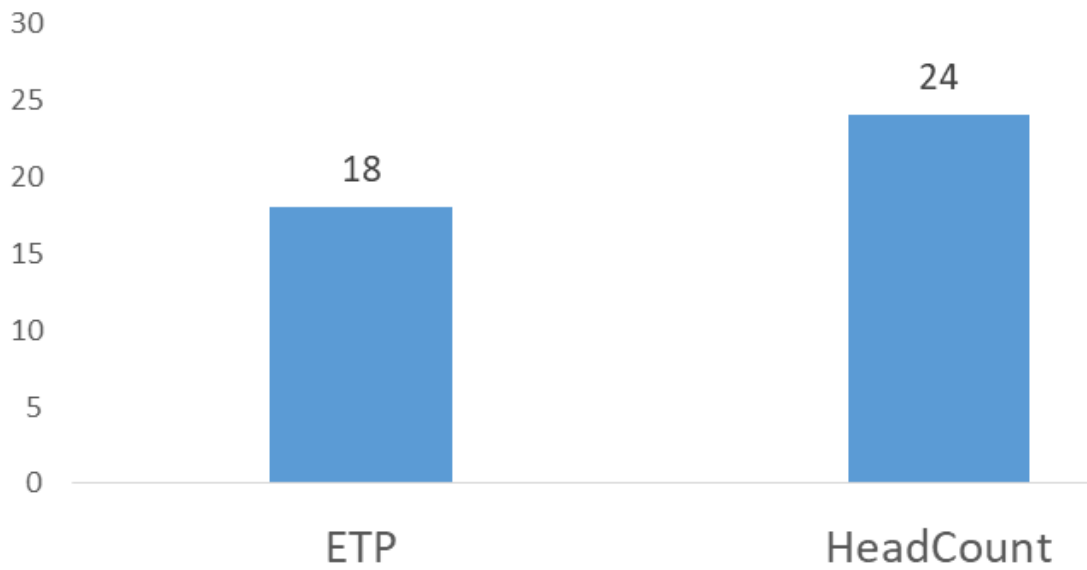



# Platforms

# Platforms Overview

PROCESSING

MATERIALS & STRUCTURES

DURABILITY

MODELING & SIMULATION

## ADDITIVE MANUFACTURING



### LMD-p

2 kW / Continuous  
5-axis motion  
Building Volume:  
600x400x400 mm<sup>3</sup>  
Protective atm

718	TA6V
625	316L
Waspaloy	15-5PH
ABD900AM	
AD730	
NiCrSiB	



### LMD-w

2 kW / Continuous  
5-axis motion  
Building Volume:  
600x400x400 mm<sup>3</sup>  
Protective atm

TA6V
316L



### EBM

3 kW / LaB<sub>6</sub>  
Building Volume: Φ 350mm / H 380 mm  
Preheating 900°C  
10<sup>-1</sup> mbar (PHe)



### LBM – ProX100

50W – 1070 nm  
100x100x80 mm<sup>3</sup>



AA-4XXX
316L

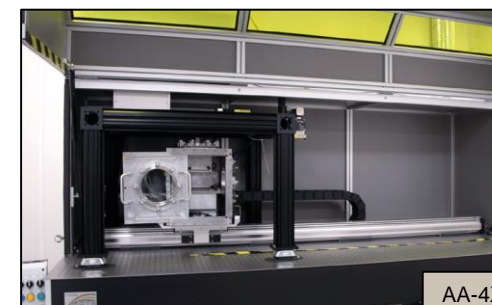

### LBM – Test Bench

700W – 1070 nm  
Ar protective gas - Vacuum  
In-situ monitoring systems  
Building Volume: 100x100x40 mm<sup>3</sup>  
Scanner or welding mode

AA-4XXX
---------

# Platforms Overview



PROCESSING

MATERIALS & STRUCTURES

DURABILITY

MODELING & SIMULATION

**(ClosedDie)FORGING**



TA6V

IBA  
Interface



TA6V

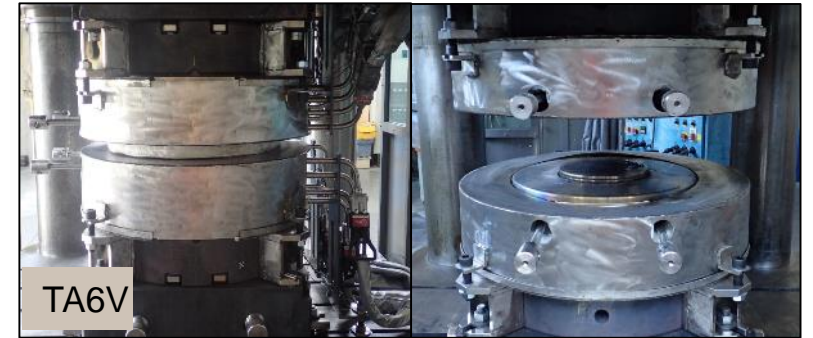

TA6V

T up to 950°C



TA6V

**Manipulator**  
Handling up to T= 1260°C  
Semi-automatic mode  
Transfer < 10 s  
Max Size :  $\Phi_{max} = 500 \text{ mm} / m_{max} = 150 \text{ kg}$

**Hydraulic Press**  
Max Load: 1000 t  
0,01 < Speed < 20 mm.s<sup>-1</sup>  
Static Load @ +/- 5%  
H<sub>max</sub> = 360mm

Force cell: 25 or 100 kN  
L<sub>max</sub> = 100mm / D<sub>max</sub> = 20mm  
10<sup>-3</sup> < v < 10<sup>3</sup> mm.s<sup>-1</sup>  
dT/dt up to 10000°C.s<sup>-1</sup>

# Platforms Overview

PROCESSING

MATERIALS & STRUCTURES

DURABILITY

MODELING & SIMULATION

## THERMAL TREATMENT



AA-4XXX  
TA6V  
718

### Hot Isostatic Press

$P_{Ar}$  up to 2000 bar

$T_{max} = 1400^{\circ}C$

$\Phi_{max} = 170mm / H_{max} = 300mm / m_{max} = 40kg$

Mo heating system & holder  
Uniform Rapid Quenching



### Series of oven & furnaces (lab scale)

$150 < T < 1400^{\circ}C$

Air and Ar environment

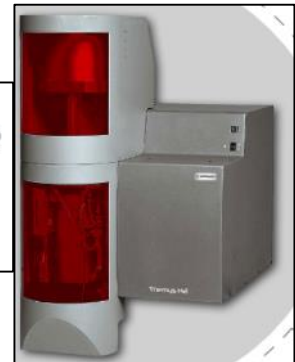

### Dilatometry and DTA

$T$  up to  $1600^{\circ}C$

# Platforms Overview

PROCESSING

MATERIALS & STRUCTURES

DURABILITY

MODELING & SIMULATION

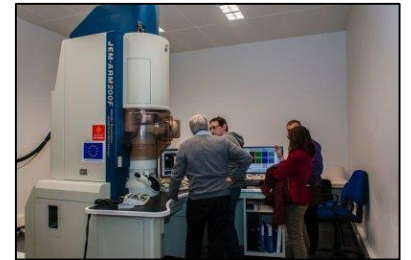
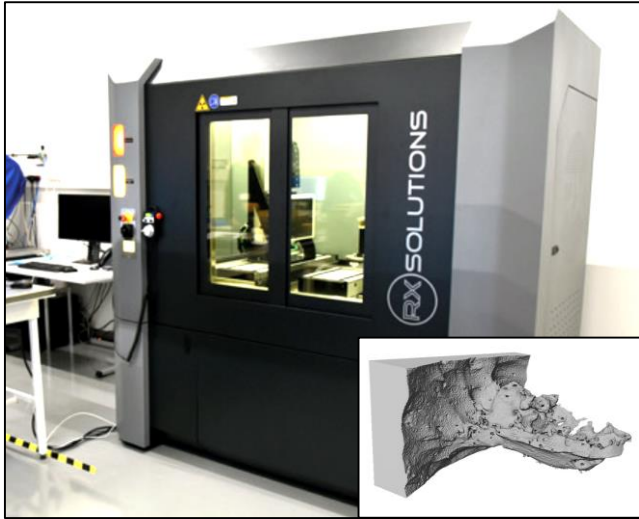

**X-Rays  $\mu$ CT Scan**  
 $\Phi_{max} = 150mm / H_{max} = 500mm$   
Voxel size =  $2\mu m$   
E = 230 kV

**SEM, Optical Microscopes,  
Confocal Microscope,  
Microhardness Tester**

**SEM, EBSD, Castaing  
Microprobe, FIB, TEM, GDOS**



# Platforms Overview

PROCESSING

MATERIALS & STRUCTURES

DURABILITY

MODELING & SIMULATION

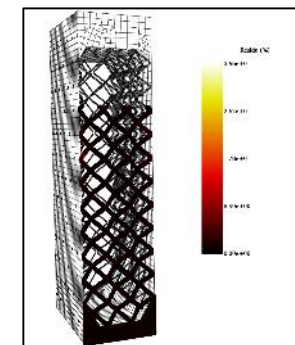

Tensile & Fatigue test machines

F = 100 kN

T up to 1300°C

Digital Image Correlation

# Platforms Overview

PROCESSING

MATERIALS & STRUCTURES

DURABILITY

MODELING & SIMULATION

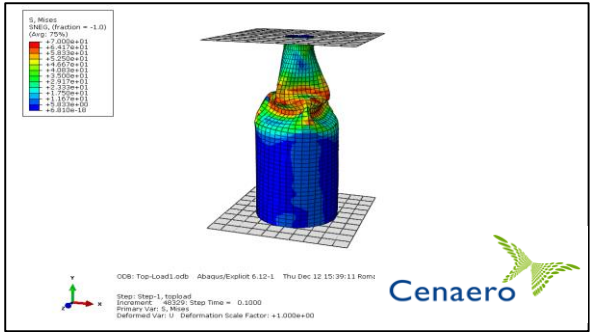

Morfeo <sup>TM</sup>



Abaqus <sup>TM</sup>

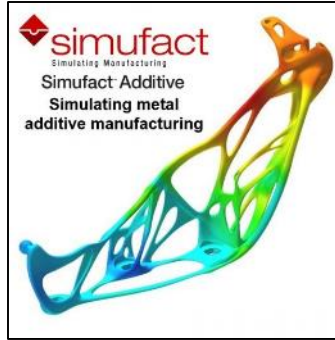

SimuFact Additive <sup>TM</sup>

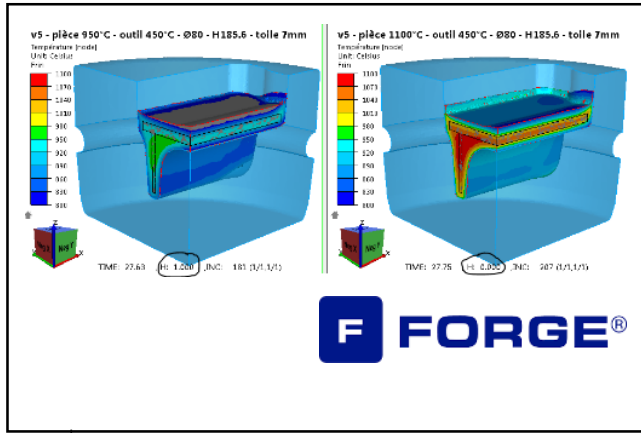

Forge <sup>TM</sup>

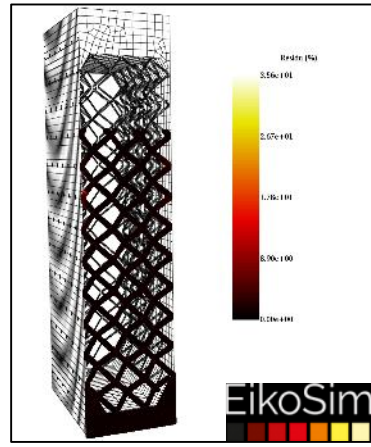

EikoTwin <sup>TM</sup>

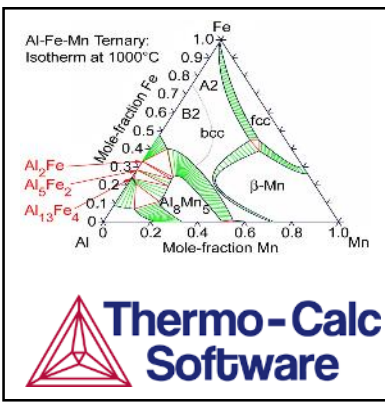

Thermocalc <sup>TM</sup>



# Projects

# Projects Overview



**METALTECHNICS**

2016	2017	2018	2019	2020	2021	2022	2023	2024
------	------	------	------	------	------	------	------	------

**ANDDURO** 16,1 M€

- PBF Additive manufacturing (LBM/EBM)
- Ti64, Ni718, Ni625, AS7G06, AAXXXX
- Support to M&P specifications
- In-situ process monitoring
- Physical metallurgy & mechanics (effect of defects)
- Thermomechanical ageing

**HIPPOME** 1,1 M€

- LBM – Ni base alloys
- HIP - Oxidation issue

**DePÔz** 6,3 M€

- Additive manufacturing (LMD)
- Ti64, Ni718
- Repair & addition of function
- Design rules

**GLAD** 1,5 M€

- FGM / LMD

**MATILD** 2,8 M€

- LMD 3D manufacturing
- Bleeds and structures – TRL6

**LASER** 0,9 M€

- Additive manufacturing (LBM)
- Architected materials (lattices)
- Thermomechanical modeling

**WALLSAPP** 2 M€

- Lattices and thins structures
- Meta-Materials design, fabrication, durability and modelisation
- Multiphysics optimisation (mechanical and thermal functions)

**MAMA** 10,4 M€

- Coupling forging & additive manufacturing
- DED w

**HYDROPLANE** 0,1M€ + ?

- AM for H2 distribution components
- Hydrogen embrittlement risk analysis

**Recet4Rail (EU Project)** 0,5 M€

- Heat exchangers for railway
- Design, manufacturing and characterization

**NextAir (EU Project)** 0,5 M€

- Heat exchangers for engines
- MDO

Closed
Running
Future

# ANDDURO.

Analysis of Defects and DURability Optimisation.

- Master Powder Bed Processes for aerospace applications
- Perform LBM benchmark
- Support M&P specifications for industrial deployment
- Increase knowledge on peculiar metallurgy of AM products
- Develop in-situ process control



17,2 M€



17/10/16  
31/08/21



## Main Activities

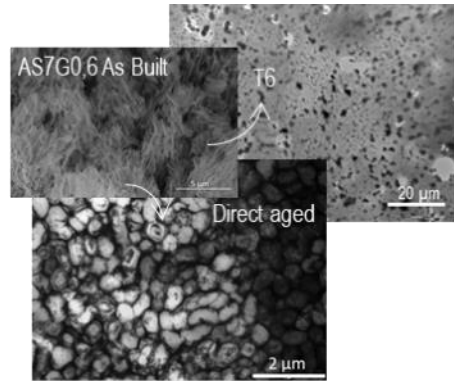

- Post fabrication optimized heat treatment: Ti64, Ni718, AS7G
- Properties evolution up to 10 000 h of thermal ageing

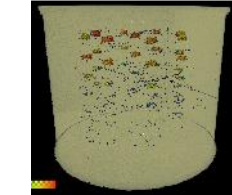
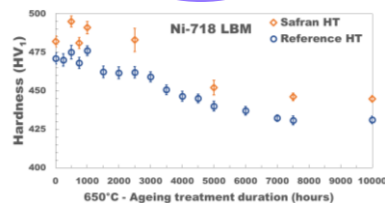
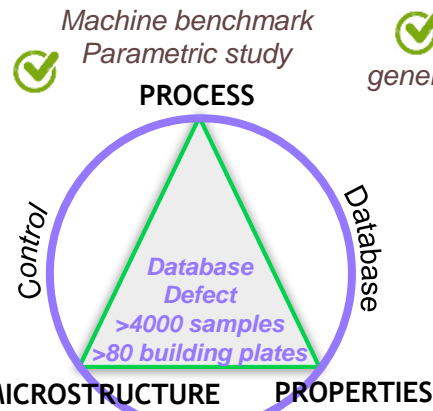

Effect of defect on mechanical properties  
HIP challenge

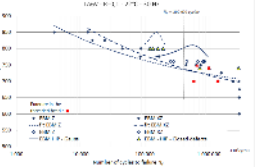

In-situ detection on OLLOPA IRT test bench

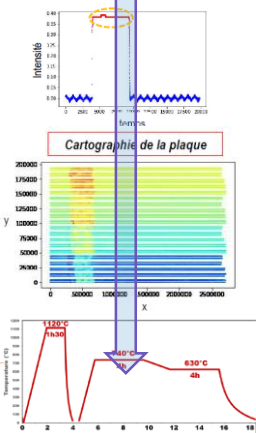

## Alloys considered

- Ti64,
- 718 alloy
- AlSi7Mg0.6,
- 625 alloy,
- AA...

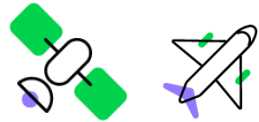

# WALLSAPP

## thin WALled and Lattice Structures aerospace APPLications



### OBJECTIVES

1. Master Manufacturing,  $\mu$ Structure & Properties of thin walled and lattice structures obtained by metal additive layer
2. Develop predictive and efficient numerical models and digital tools
3. Develop capabilities to design and manufacture lightweight and multifunctional structures integrating thin walled and lattice for aerospace environments

€ 2 M€



36 months  
May 21 – May 24



ICA



THALES ALENIA SPACE,  
LIEBHERR, AIRBUS,  
LAAM, ALTRAN

IRT Staff: 9

### Our Approach

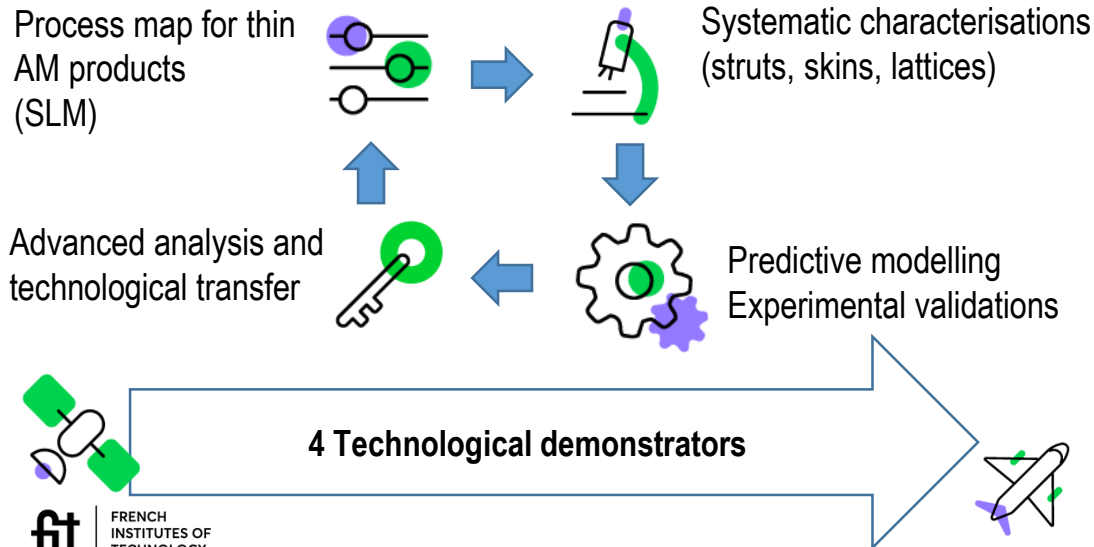

### Project Structure

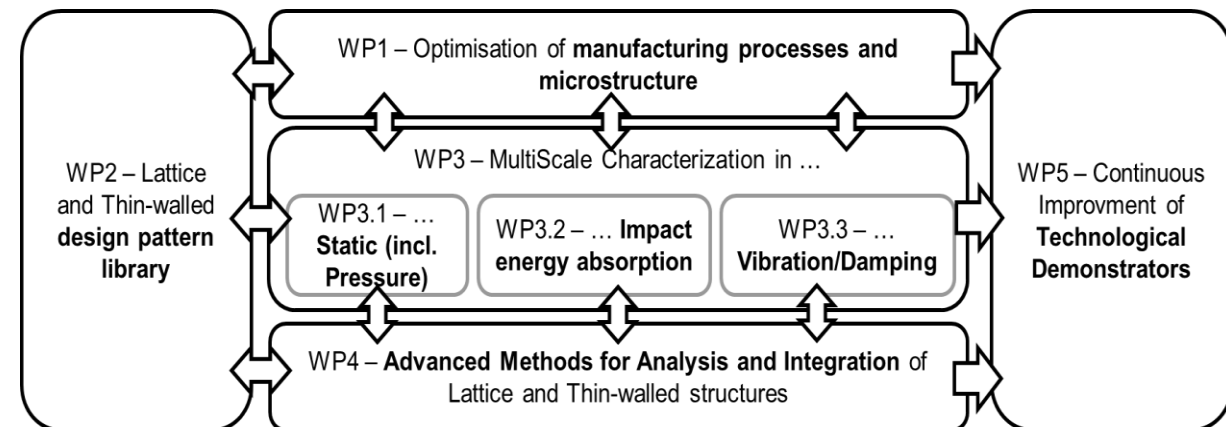

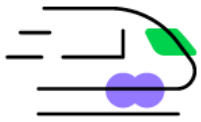

# RECET4Rail

## Reliable Energy and Cost Efficient Traction for Railway Work Stream 1 → 3D additive manufacturing and new manufacturing technologies



### OBJECTIVES

1. Identify where AM technologies can contribute to traction drive system development.
2. Improve conception lead-time, prototype manufacturing through a multidisciplinary design optimisation workflow.
3. Workflow application for a newly designed AM part.

€ 520 K€



30 months  
Dec 20 – May 23



ICAM



ALSTOM, AKKA

IRT :

Advance manufacturing technologies  
+  
Methods & tools for the development of complex systems

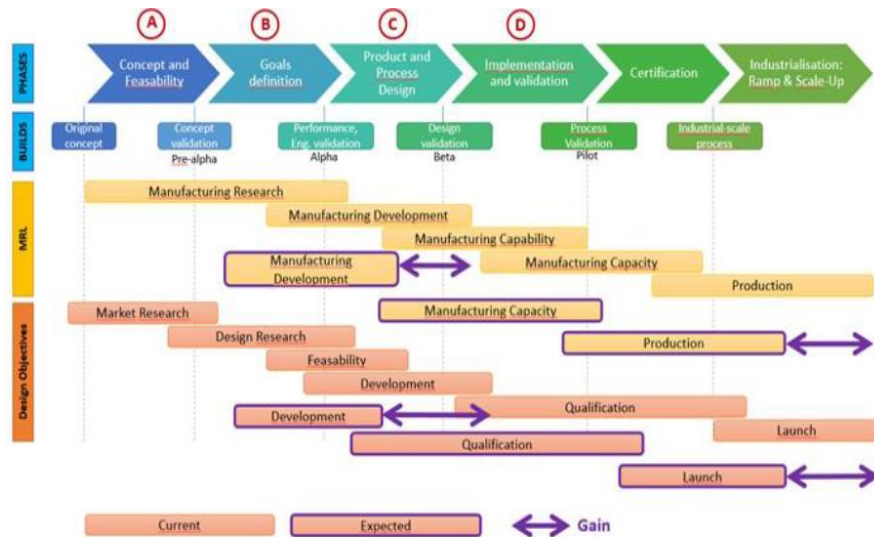

Expected gain with MDO design for Additive Manufacturing

### Application case example

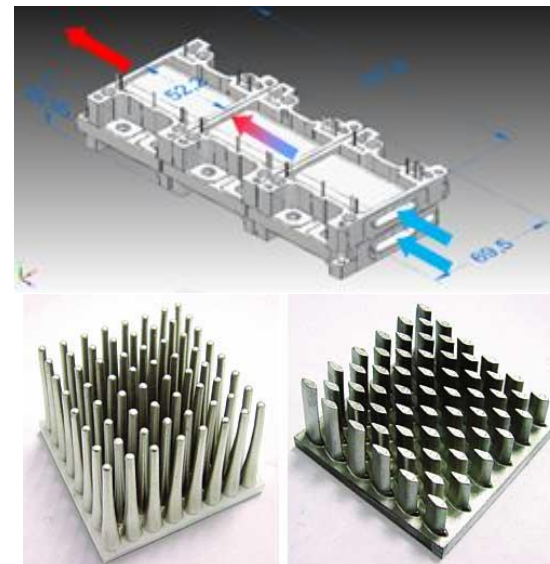

Complex state of the art pin heat sinks (metal injection)

Multi-disciplinary optimisation  
+  
Additive manufacturing design opportunities

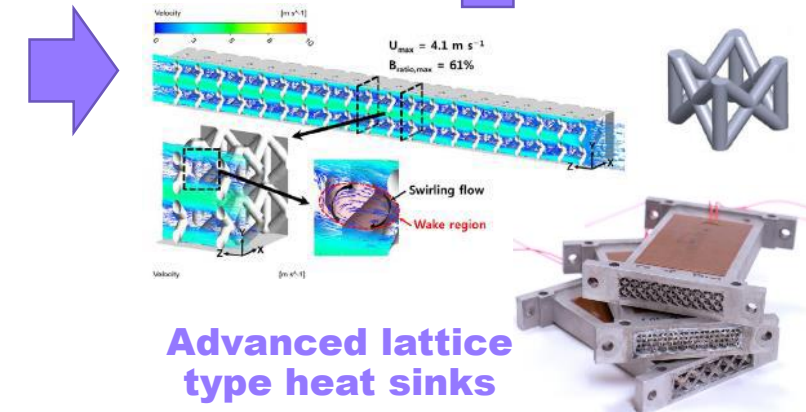

Advanced lattice type heat sinks

# HYDROPLANE

*HYDROgen Propulsion Leveraged by Additive manufacturing for Next zero Emission aircraft*



Hydrogen distribution systems for new generation of aircraft



PIA project



Q4-22/Q1-23  
Duration : 46 mois



ROE ~ 4 M€



PIA: 2 M€

## Stakes / Industrial needs

- Design and manufacturing of H<sub>2</sub> distribution systems in ZEA
- Additive manufacturing as a new player for complex and integrated design and mass reduction
- AM materials database required for design
- Avoid any Hydrogen embrittlement risk

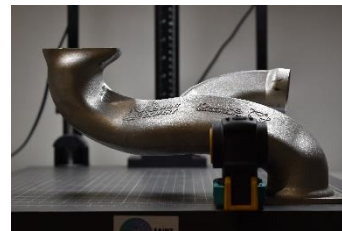

## R&T Activities

- Establish design guidelines linked to AM technologies (LBM) to avoid any scrap and reduce manufacturing cost
- Evaluate and quantify surface aspects: properties inherited from design and process parameters (roughness, microstructure, chemistry, etc...)
- Evaluate chemical treatments on surface properties evolution
- Mechanical and microstructural databases for 316L SS transformed by LBM process
- Methods and tools to evaluate Hydrogen embrittlement sensitivity
- Develop material alternative to 316L SS

# HIPPOME.

## Hot Isostatic Pressing solutions for Powder Metallurgy

- Study of the reactivity of Ni-based super alloy during Hot Isostatic Pressing (HIP)
- Development of atmosphere control solutions for HIP
- Heat treatment cycle time optimization



1,18 M€



24 Months  
04/05/2021  
30/04/2023



ACADEMIC:



COLLABORATIVE:



5 People  
(1 Post-Doc)

### Members Interests

Additive manufacturing and Metal Injection Moulding (MIM) parts require HIP to ensure desired material properties

Contamination sources during HIP not well identified yet, problem during assembly operations

Oxidation kinetics at high P and T not well understood

## WBS

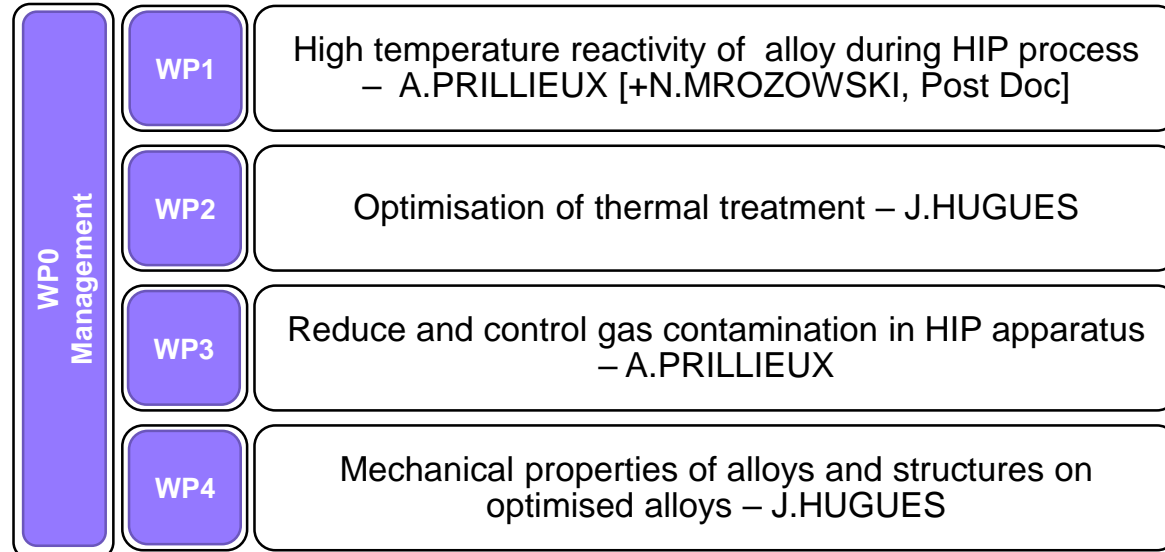

# DEPOZ.

## Analysis of Defects and DURability Optimisation.



- Master LMD process for aerospace applications
- Repair & functionalization
- Support M&P specifications for industrial deployment
- Increase knowledge on peculiar metallurgy of AM products
- Process simulation & multiscale modelling



### Main activities

- Design guidelines
- Process maps
- Process simulation
- Materials allowable & behavior laws
- Multiscale microstructures characterizations incl. interface
- Thermal treatments specifications
- Defects & NDT strategy vs. targeted application
- Databases: Materials properties & Defects
- Full scale demonstrators



5,7M€



17/10/16  
31/08/21



AIRBUS, ALTRAN, BEAM, ELEMENT, IREPA LASER, LATÉCOÈRE, LAUAK, LIEBHERR, MECAPROTEC, OERLIKON, POLY-SHAPE, SATYS, SAFRAN, TIMET



21 Deliverables



5,2 FTE



1 Publication/  
9 Workshops

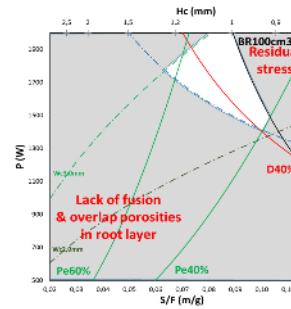

Machine Variability  
Parametric study



Building strategy vs.  
macro & microstructure



In Situ Monitoring  
Camera infra rouge

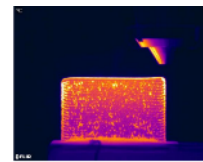
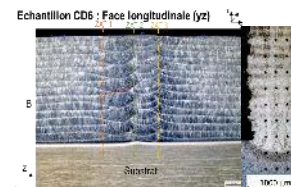

### Alloys studied: Ti64 et Ni718

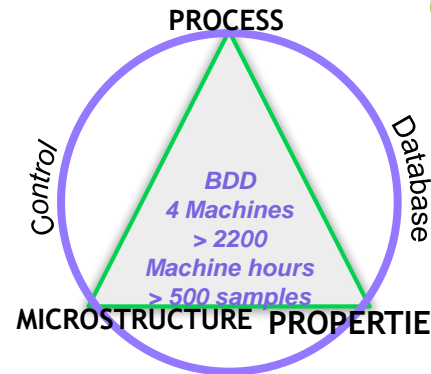

Optimized Building strategy



Paramètres standards



Paramètres DePoZ optimisés



WP1 Proof of concept



Polyshape



Defects vs. building strategy

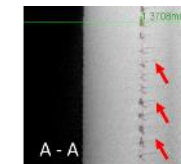

A - A

# GLAD.

functionally Graded materials with Laser metal Deposition

## → Development of functionally graded materials for an aeronautical

- Laser Metal Deposition (LMDp)
- Two couples of materials : Nickel alloys
- Powder delivery system (TRL5)
- Characterization methods specific to graded materials : chemical, metallurgical and mechanical properties
- Specific heat treatments of each material couples
- Design, manufacturing and characterization of an industrial part (LEAP's casing)



1,485 M€



36 Months  
24/05/2021  
23/05/2024



AddUp  
GLOBAL ADDITIVE SOLUTIONS



AddUp | Poly-Shape | BeAM  
AddUp, a Fives & Michelin joint-venture.



11 People  
(1 Post-Doc)



# WBS

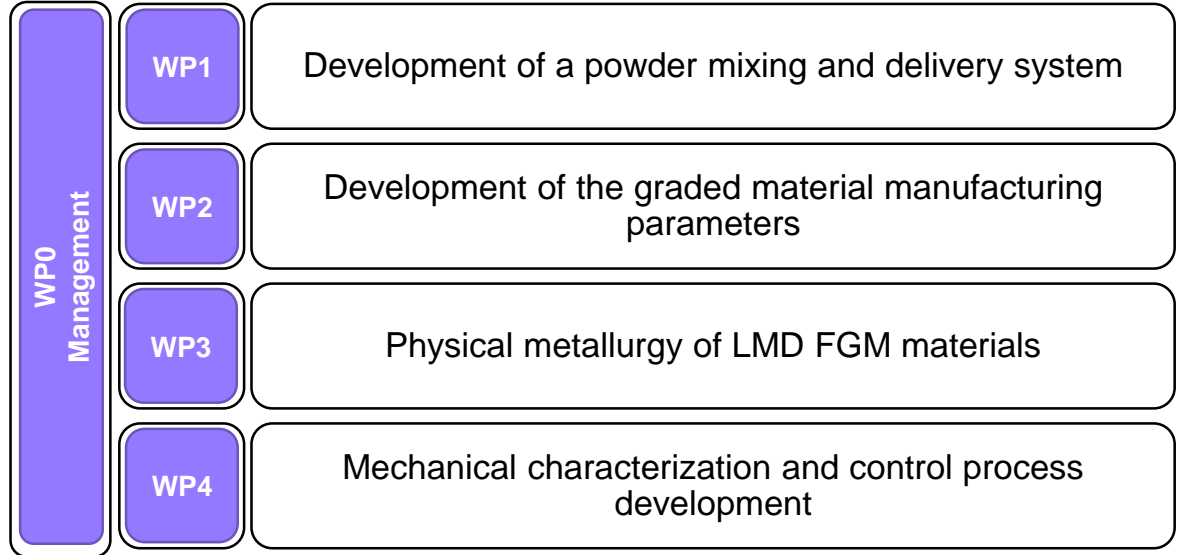

# MAMA

## Metallic Advanced Materials for Aeronautics



- Cut manufacturing cost of Ti64 structural parts : TRL6 to be validated on both hot and cold processes (forging, machining, ...)
- Reduce the cost of repair of Ti64 parts through additive manufacturing
- Reduce the cost of repair of forging dies through additive manufacturing



10,2 M€



60 Months  
07/2018  
07/2023



Airbus, Aubert&Duval,  
Sciaky, Mecaprec, Reaéro,  
Opt'Alm, Région Occitanie

ACADEMIC:  
ENIT, CIRIMAT,

### 3 levers for main objective

- Closed-die-forging in  $\beta$  domain instead of  $\alpha-\beta$  :
- Simplify billetizing route & investigate the use of recycled Titanium
- Couple AM & Forging processes

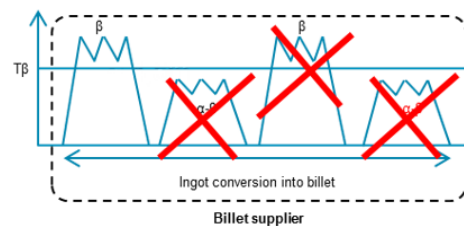
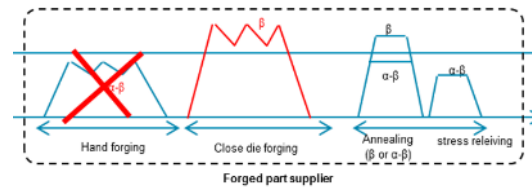

### Main activities

- R&T forging platform

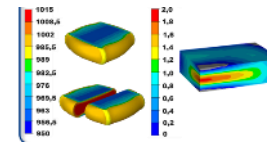

- Handling at temperature up to 1260°C
- Tranfer form furnace in less than 10s
- Part up to  $\phi=500\text{mm}$  and 150kg

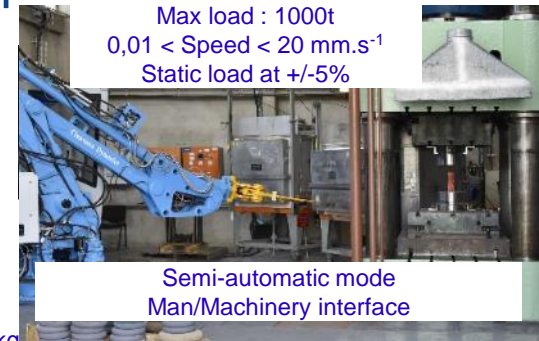

Max load : 1000t  
0,01 < Speed < 20 mm.s<sup>-1</sup>  
Static load at +/-5%

Semi-automatic mode  
Man/Machinery interface

- Metallurgy, microstructures & associated mechanical properties

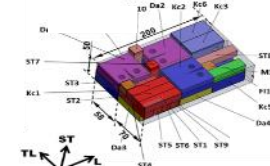

B.Max, 2018



V. Renon, 2018

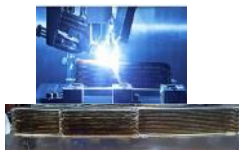



**End**