

Visit of UKAD / EcoTitanium to Derby

June 2018

© 2018 Rolls-Royce plc

The information in this document is the property of Rolls-Royce plc and may not be copied or communicated to a third party, or used for any purpose other than that for which it is supplied without the express written consent of Rolls-Royce plc.

This information is given in good faith based upon the latest information available to Rolls-Royce plc, no warranty or representation is given concerning such information, which must not be taken as establishing any contractual or other commitment binding upon Rolls-Royce plc or any of its subsidiary or associated companies.

Trusted to deliver excellence



Rolls-Royce

Agenda

Introductions

Presentations of UKAD & EcoTitanium

- Process
- Product range
- Strategies
- Ramp-up

R-R titanium strategy

- GSE participation/RFQ expectations
- Products
- Volumes

R-R approval process

Revert

Next steps



Rolls-Royce

Overview of Titanium requirements

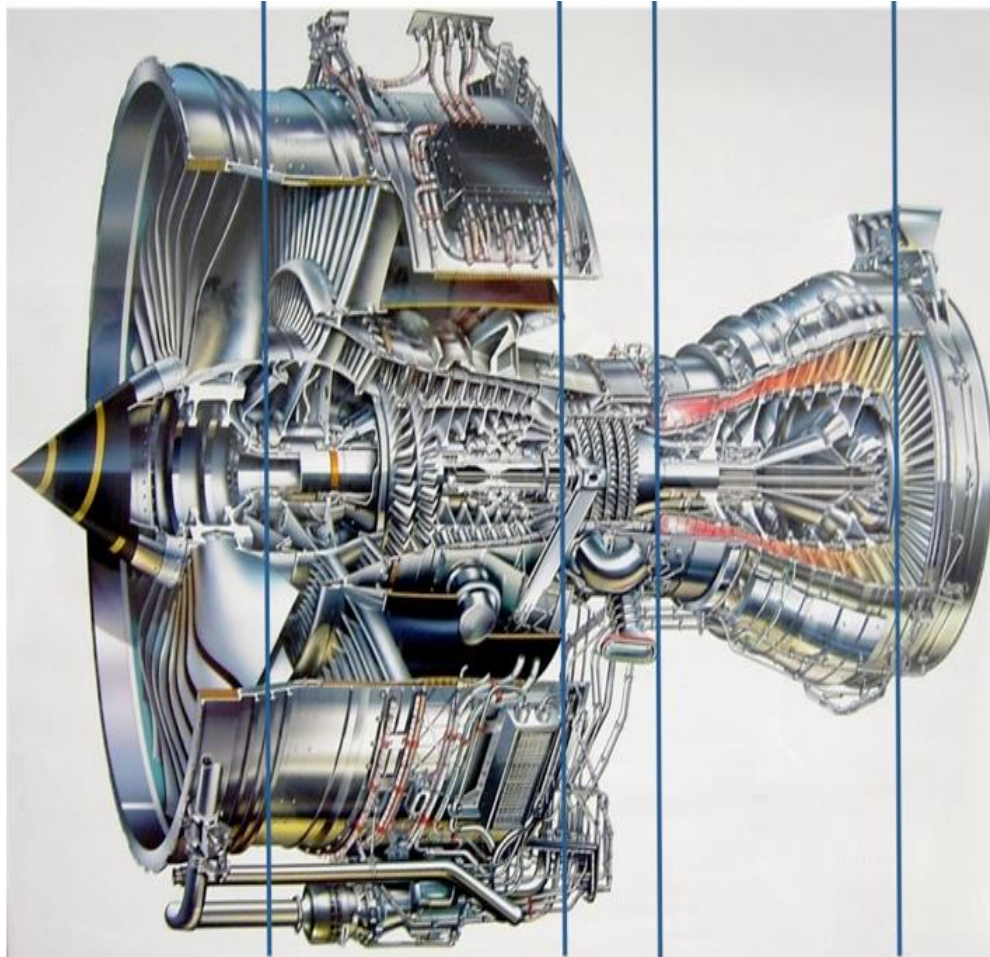

Raw material

Master Alloy



Sponge



Revert



Direct



- FLAT Products
- PQ & SQ plate
- High value add products

Indirect



- ROUND Products
- SQ & DQ to R-R spec
- Ti6-4, Ti6246
- Ti6242, Ti834 and others
- Directed-buy policy

New technology



- Alloy development
- Manufacturing technology



Notes

- Supply chain USA, Europe & Asia
- Main contracts run to end 2020
- Globally competitive
- Approval to MSRR/RRMS specification range
 - Eg MSRR8652 : ingot, bingot, billet and bar
- Position on flat products? Eg MSRR8633 / 8632
- DQ – Rigorous pedigree/ track record required



Titanium global RFQ process

- 2018 Q3/Q4 timeframe
- Formal process via SAP Sourcing tool
- NDA
- New contract format (Framework Agt + Deliverables Agt)
- T&Cs in parallel with numbers
- Site visit, esp technical
- Commercial contact : Faye Treadwell →Carl Maitland

