

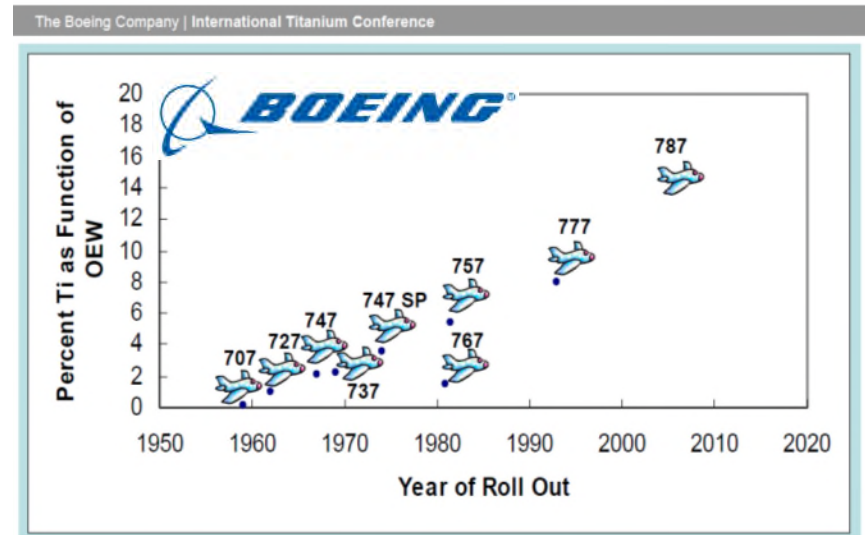

Jun 2017
UKAD and EcoTitanium

The creation of **UKAD** was allowed by :

- the increase of Ti material in airplane structures

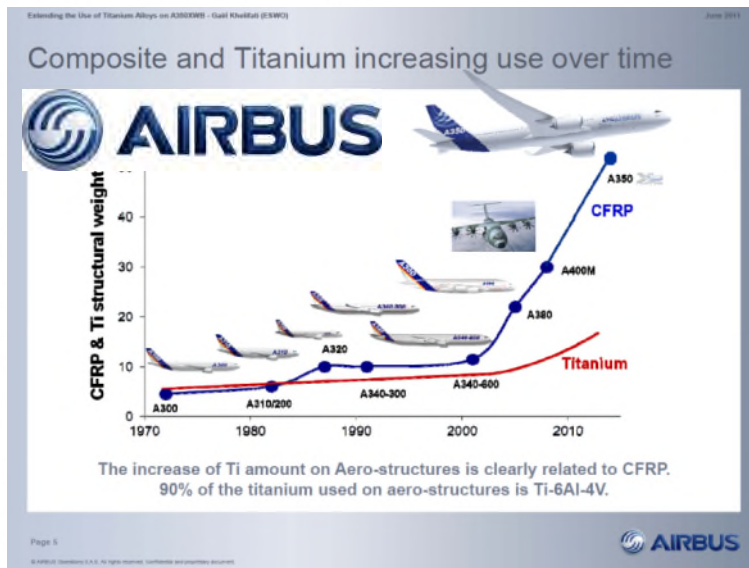

The creation of **UKAD** was allowed by :

- the increase of Ti material in airplane structures
- the **UKTMP** strategy with Ti downstream development
- the **Aubert et Duval** strategy with Ti upstream development
- the **Airbus** support with a 10 years sales agreement
- the french local authorities support

UKAD

UKAD

is a joint-venture which combines, in the titanium market, the forces of 2 companies :

➤ **Aubert & Duval**



➤ **UKTMP**



UKTMP is a Kazakh registered company. Well known for its high level of Titanium sponge quality :

1. Ilmenite mining operation
2. Titanium slag production
3. Titanium tetrachloride and magnesium production
4. Titanium sponge production
5. Titanium melting facility





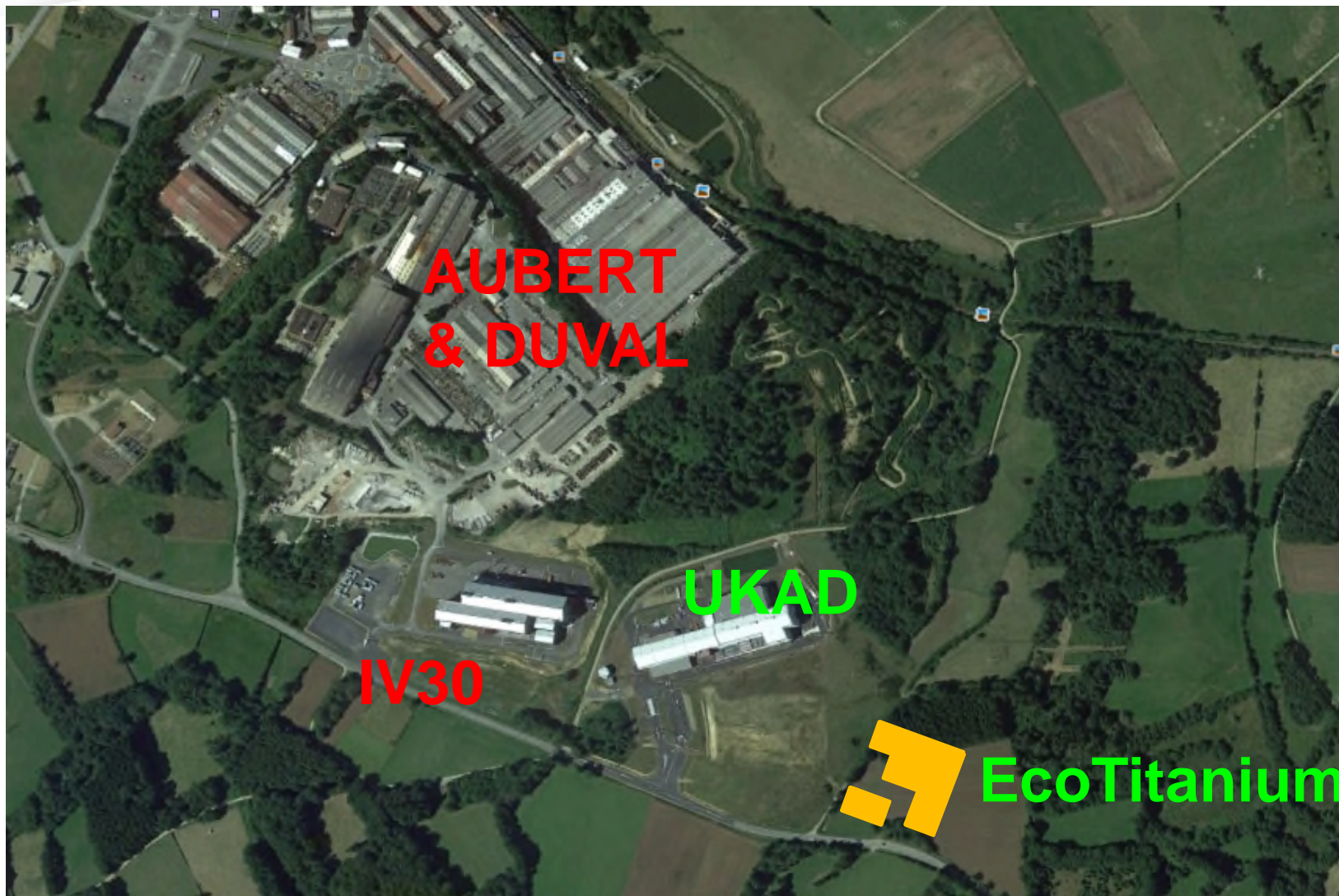

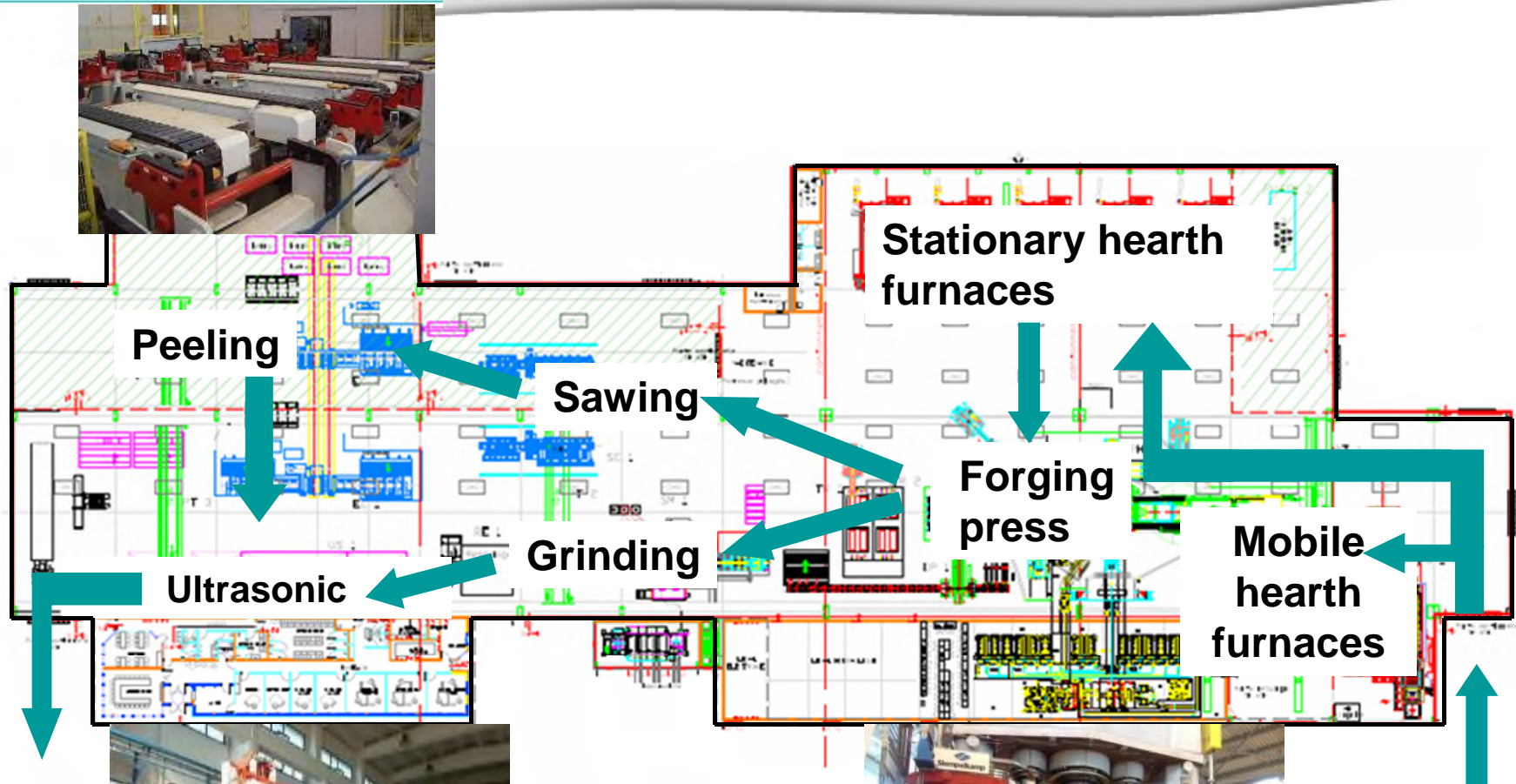

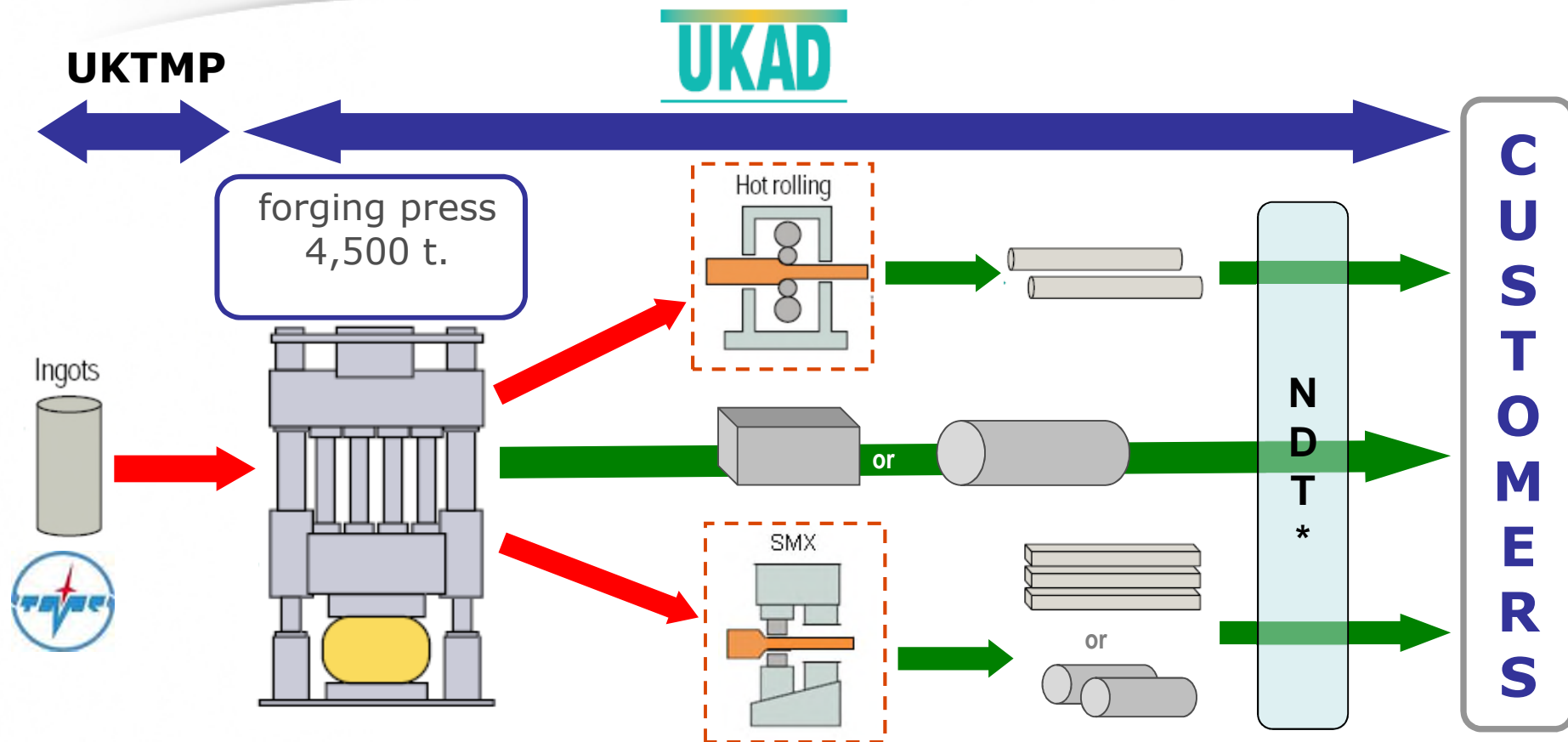

→ UKAD :

- Ingots from 7 (titanium) to 18 t
- Blooms and billets from 85 to 450 mm in Ø and 4 to 6 m long
- Bars from 55 to 85 mm

*Non destructive tests (automatic multi-element ultrasonic)

Operations subcontracted to Aubert & Duval

UKAD

Worldwide Aeronautical Market

UKTMP



Ti Alloy Ingot



UKAD

Billets

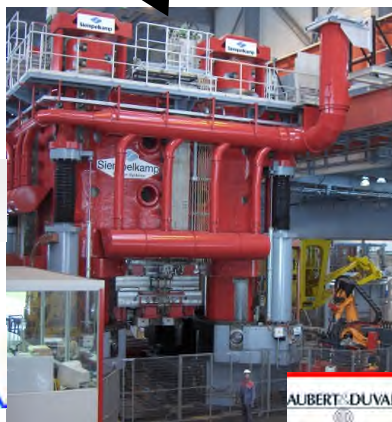

CUSTOMERS



UKTMP



Ti CP or Ti Alloy Ingot

UKAD

Ingot → Blooms, Billettes



CUSTOMERS

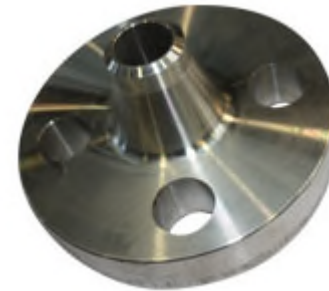

Welding Neck



Covers and flanges



UKTMP



Ti Alloy Ingot

UKAD

Ingot → Blooms → Bars

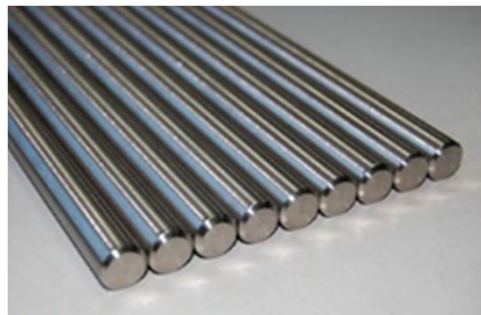

CUSTOMERS

Aeronautical fastening market

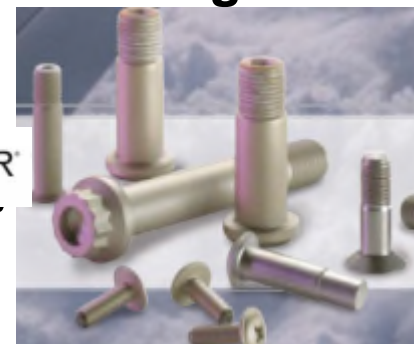

Orthopedic Implants



Knee



Hip

Confidential

UKAD Deliveries

Impact of the build-up of a strategic stock for our main customer.

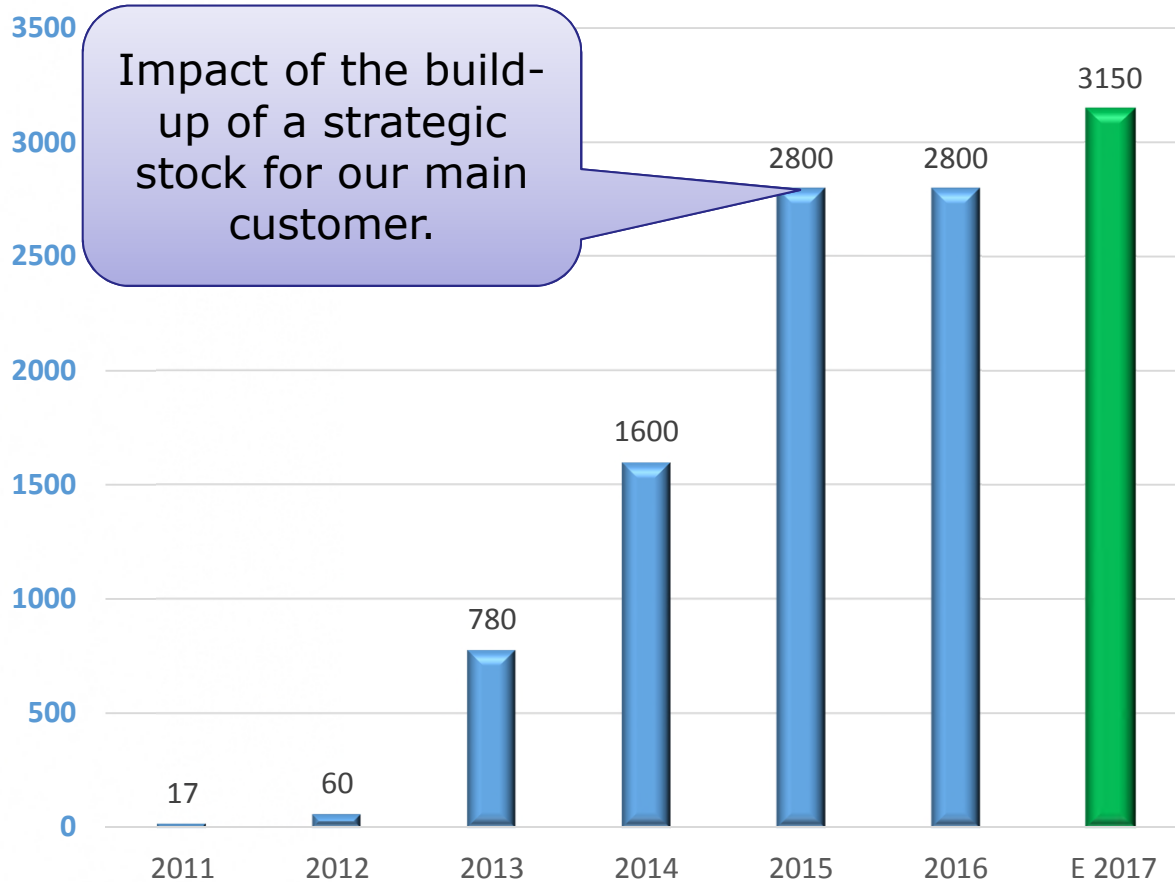

UKAD is investing in a building extension in order to put new heating furnaces for increasing its capacity. New furnace available in September.

- 2011
- 2012
- 2013
- 2014
- 2015
- 2016
- E 2017

- ISO 9001 and AS 9100, last approval Nov 2016
- ISO 14 001 and OHSAS 18001, last approval NOV 2016
- Ultra Sonic Nadcap Certification in Dec 2014, confirmed in Nov 2015 and in Dec 2016
- **Airbus :**
 - IPCA Janv 2013 « C » → IPCA+ 28 Janvier 2016 « B »
- **Boeing :**
 - UKTMP has been formally qualified in August 2015.
- **UKAD** delivers billets and bars in accordance with **AMS 4928** and Ultra Sonic tested in accordance with **AMS 2631**.

UKAD

UKAD :

For the second year UKAD was awarded by Airbus :

Best Improver Award 2015 .



Best Improver Award

UKAD

For demonstrated improvement of performance in 2015,
Strong continuous improvement and customer-oriented approach,
In line with Airbus targets and expectations.

Klaus RICHTER
Chief Procurement
Officer AIRBUS Group
& AIRBUS

Olivier CAUQUIL
Senior VP,
Head of Material and
Parts Procurement
Chairman of the Airbus
Group Material board

Thomas MOIK
Senior VP,
Head of Procurement
Operations

Thierry VILLEQUEZ
VP Supply
Chain & Quality
Procurement Operations
Material & Parts



© AIRBUS S.A.S. 2015 - photo by Master Films /C. SADONNET



Partnerships form an integrated Titanium Solution

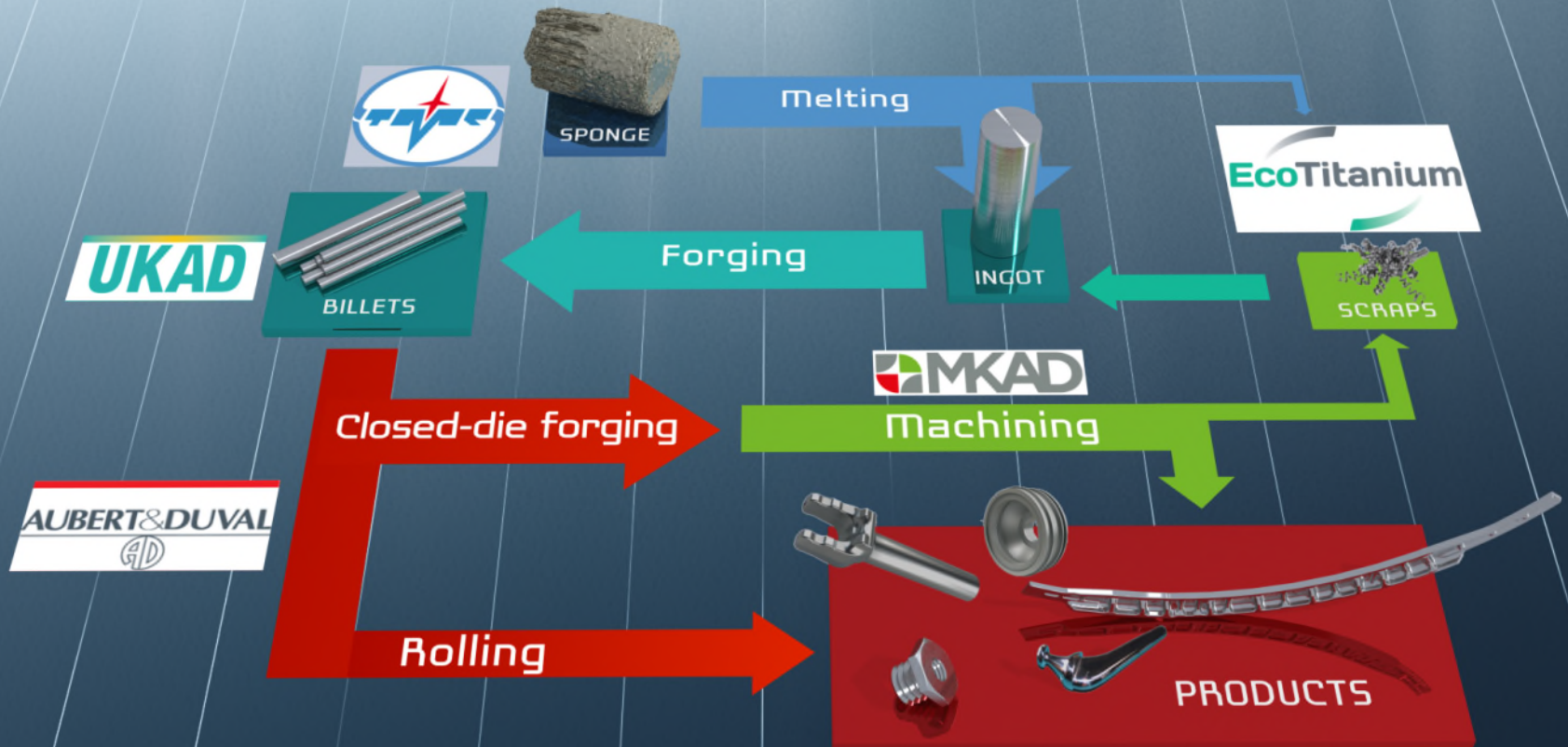

A FULLY INTEGRATED SOLUTION FOR TITANIUM

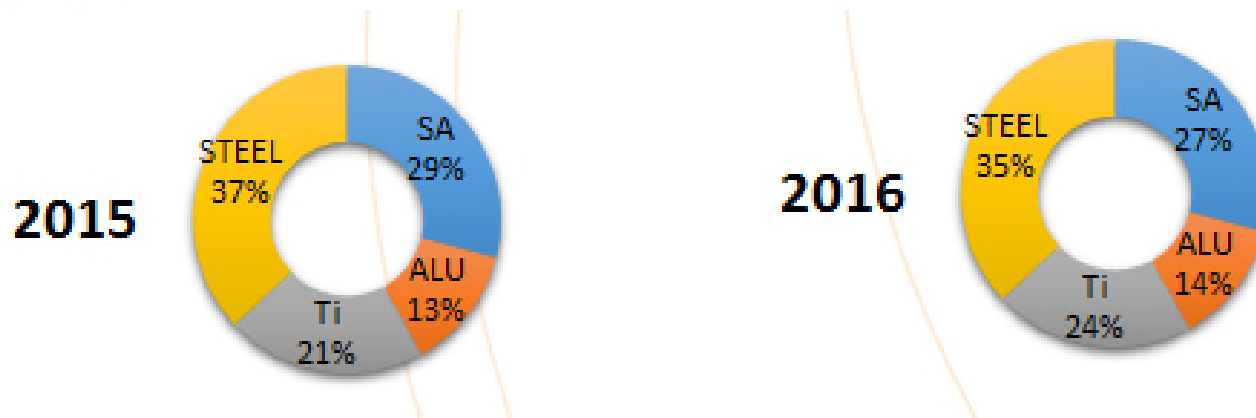

3

- Titanium represents **24%** of A&D sales in 2016
- Coming from 18 % in 2014 and 21 % in 2015.

Production generates significant volume of scrap

Titanium closed die parts generate huge volume of scrap

Billet 200kg



Closed Die Part 150kg

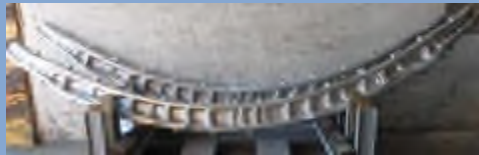

Finished Part 20kg



Ratio Buy to Fly : 10

Scrap generated in Europe is a key for competitiveness of US titanium melters

European titanium scrap is mainly exported to USA : and 11 850 tons in 2015, 10 500 tons in 2016.

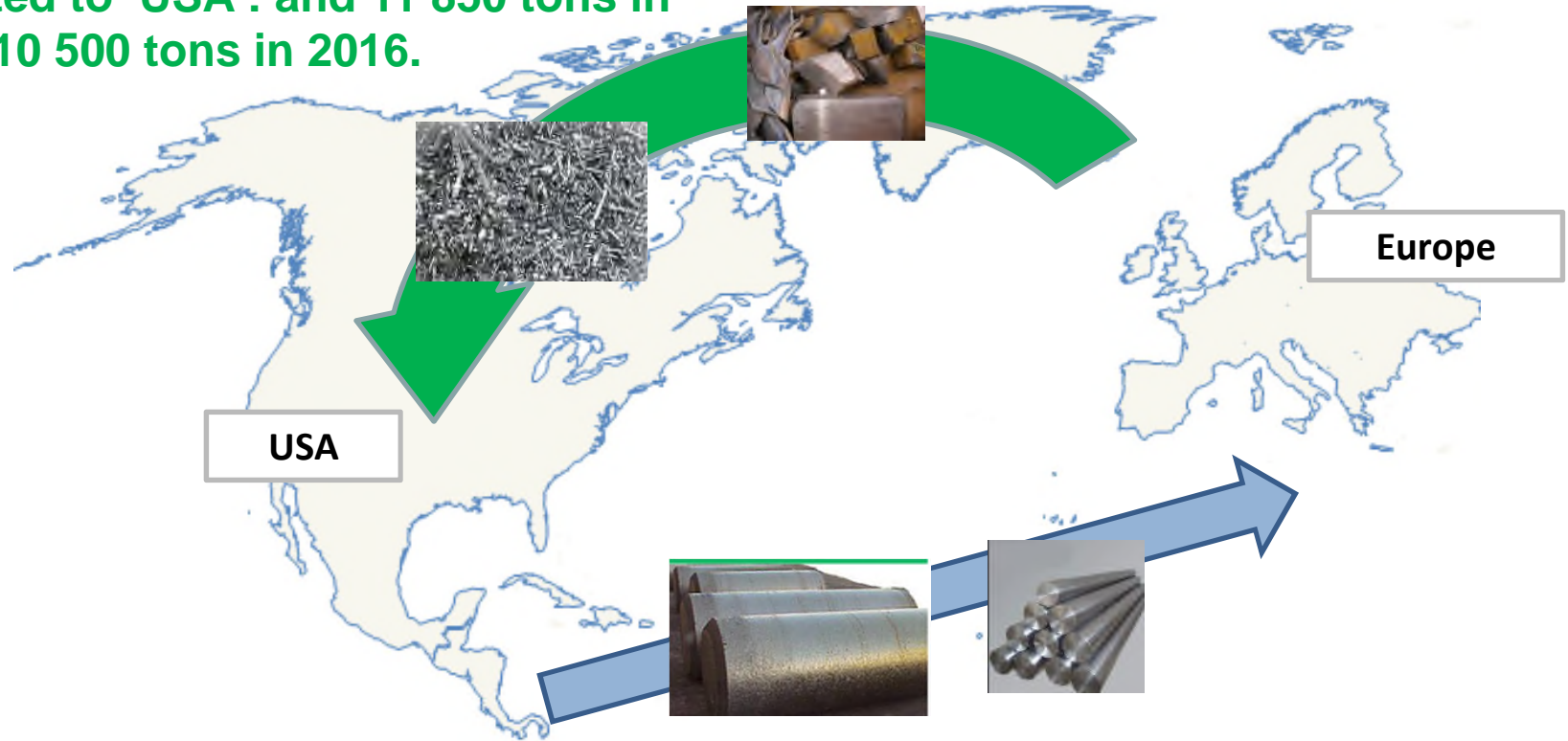

US ingots were mainly produced from titanium scrap in 2014, 2015 and 2016, more than 60 % of the total consumption Scrap + Sponge.

Committed shareholders in EcoTitanium

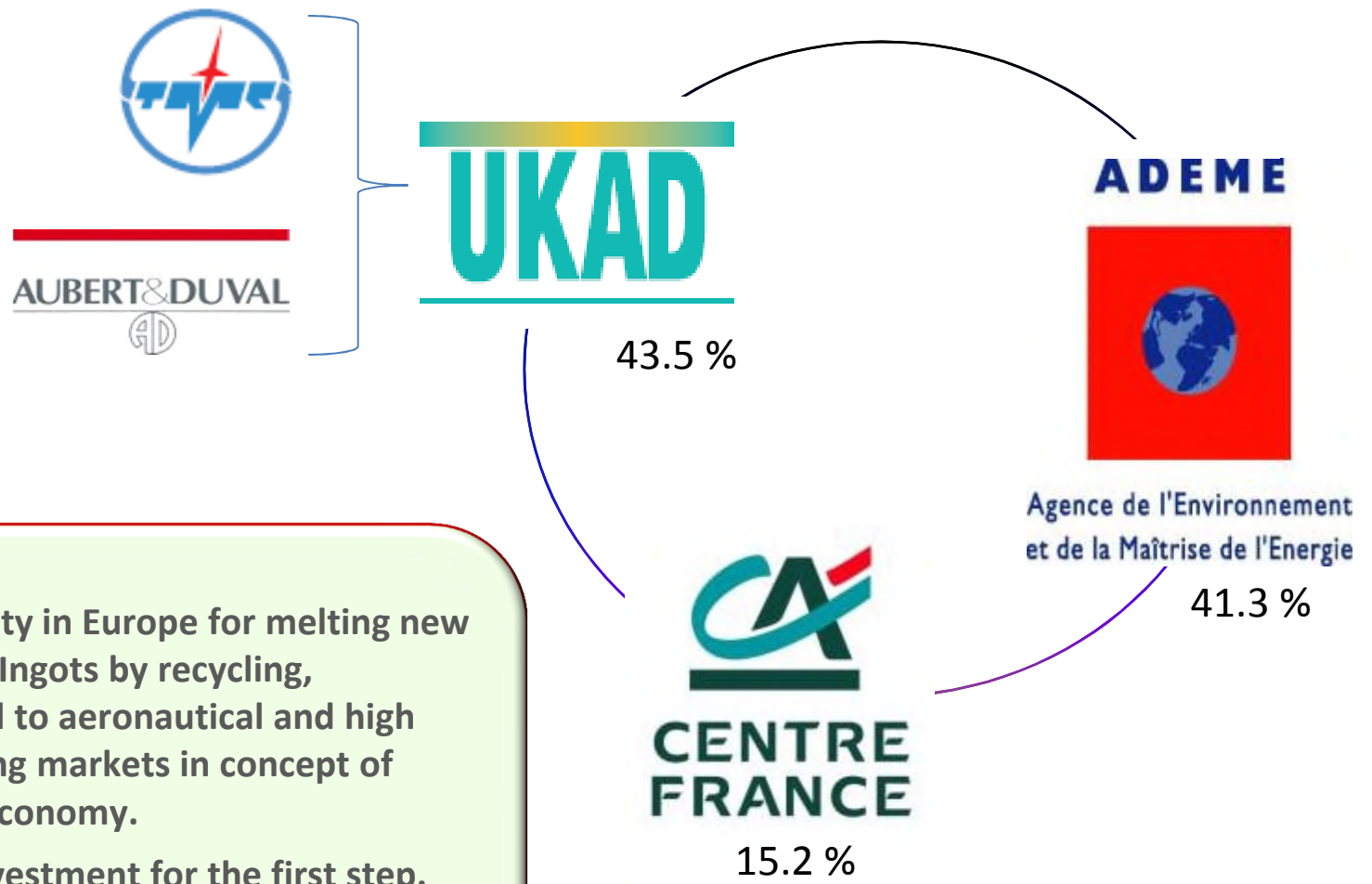

- First facility in Europe for melting new Titanium Ingots by recycling, dedicated to aeronautical and high demanding markets in concept of Circular Economy.
- 49 M€ investment for the first step.
- 63 direct employees
- 7 000 m²

Main Equipment : A Plasma Furnace Cold Hearth Refining

Loading system for turnings briquets

Loading system for solids

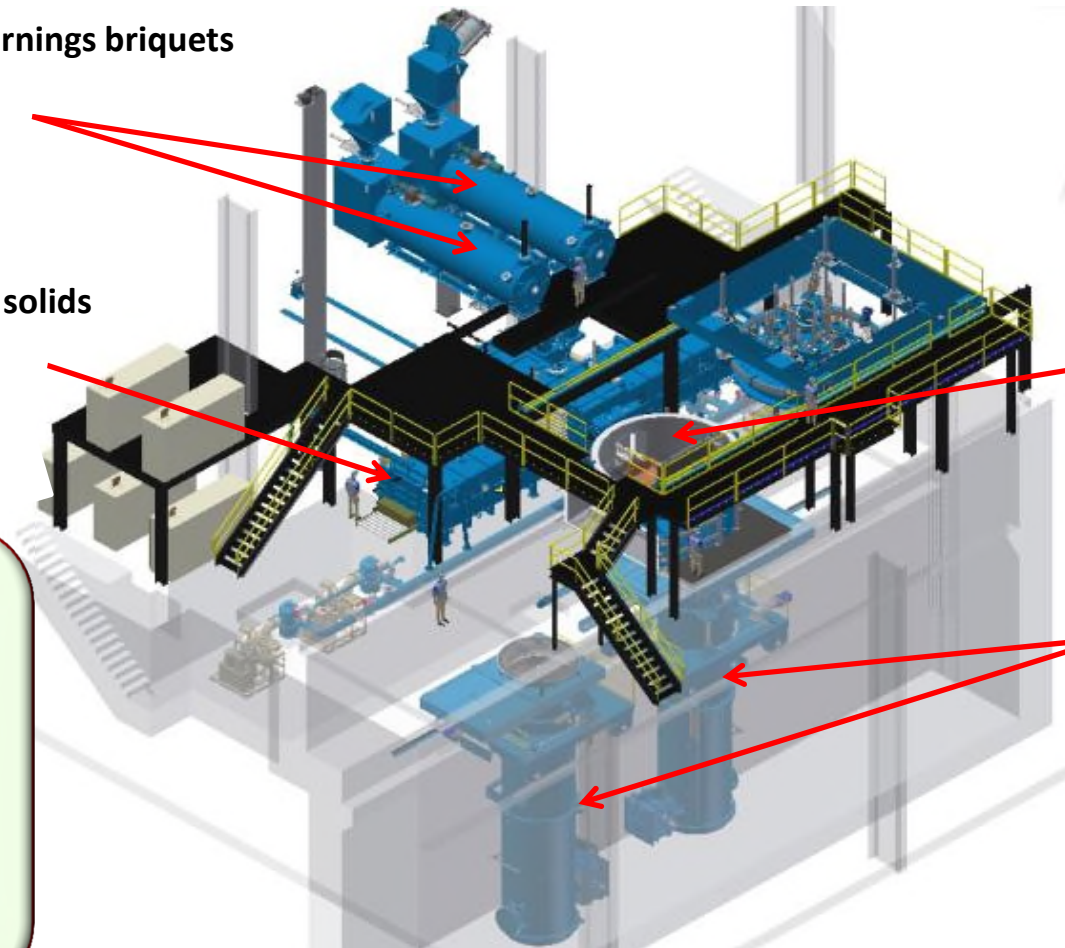

Melting Chamber

Electrodes erection chamber

- Plasma melting is followed by VAR remelting in EcoTitanium facility.
- All equipment available in Ecotitanium for preparation of melting and remelting, and sample collection for chemical analysis.

Principle

Principle of a PAMCHR furnace.

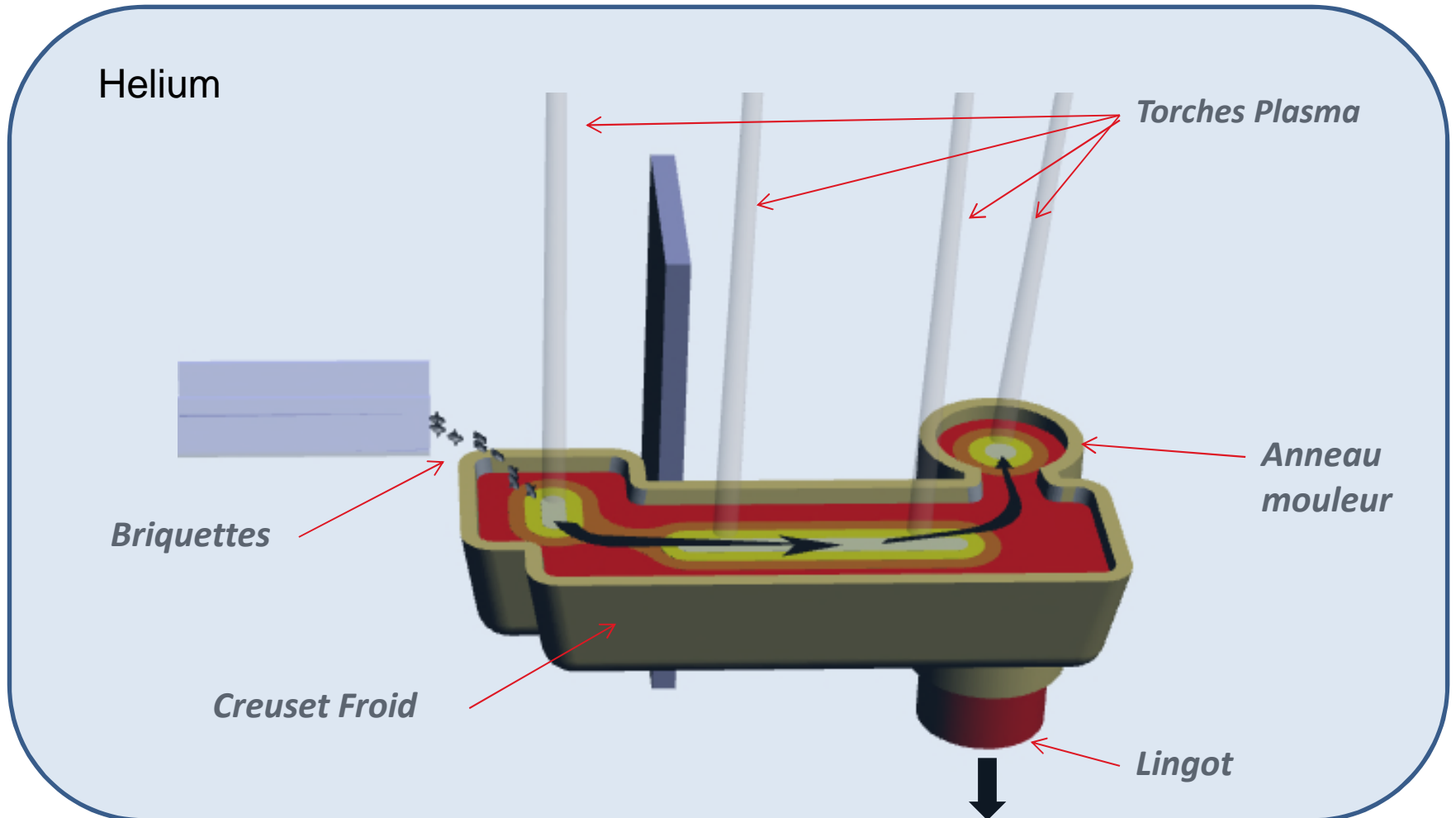

Melting 1700 °C

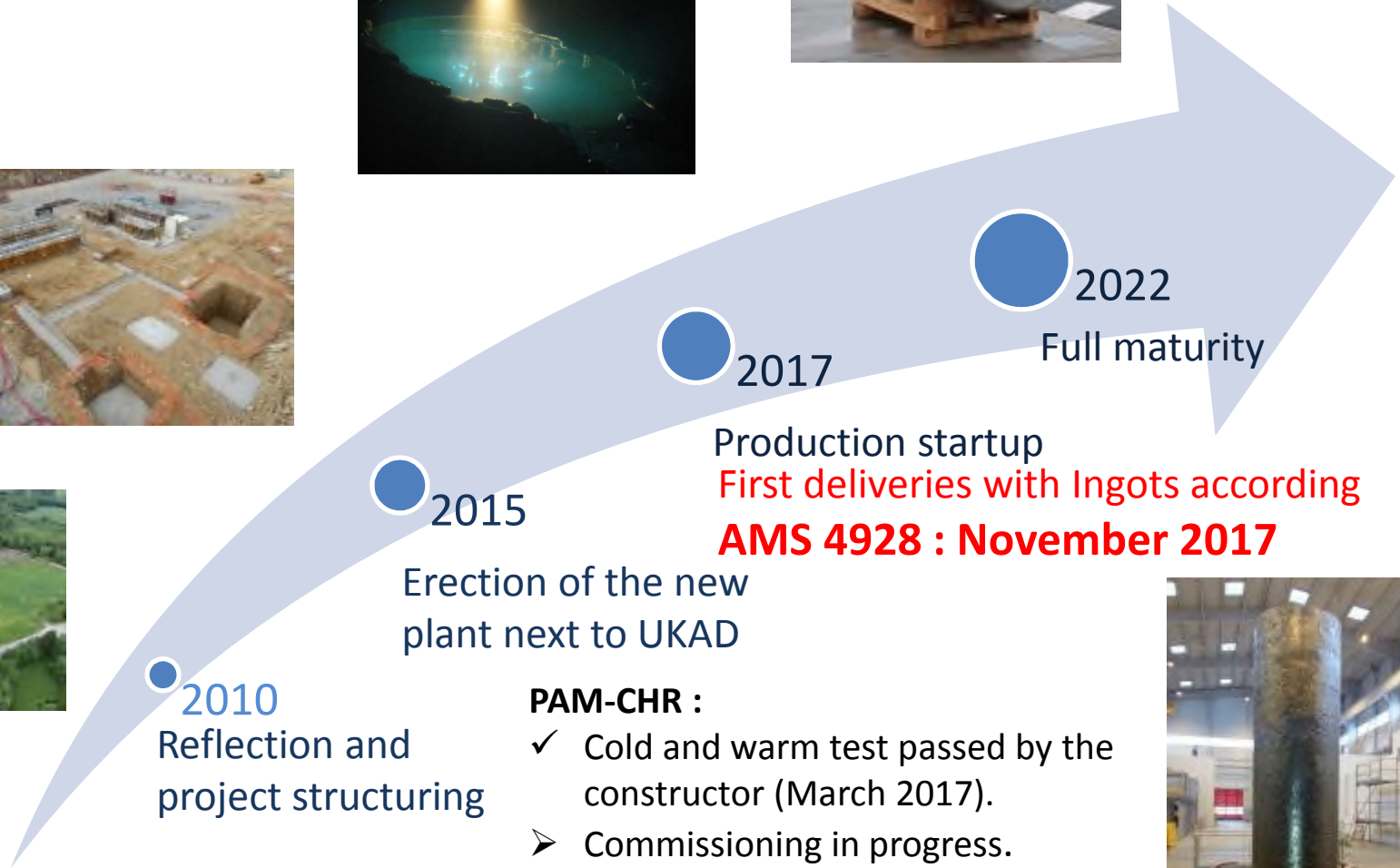

2010
Reflection and project structuring

2015
Erection of the new plant next to UKAD

2017
Production startup
First deliveries with Ingots according
AMS 4928 : November 2017

2022
Full maturity

PAM-CHR :

- ✓ Cold and warm test passed by the constructor (March 2017).
- Commissioning in progress.

VAR :

- Beginning of warm tests in June.



EcoTitanium planning

An open Solution for all UKAD Customers

The revert loop will be available for all UKAD's customers (forgers, extruders,...), based on circular Economy.

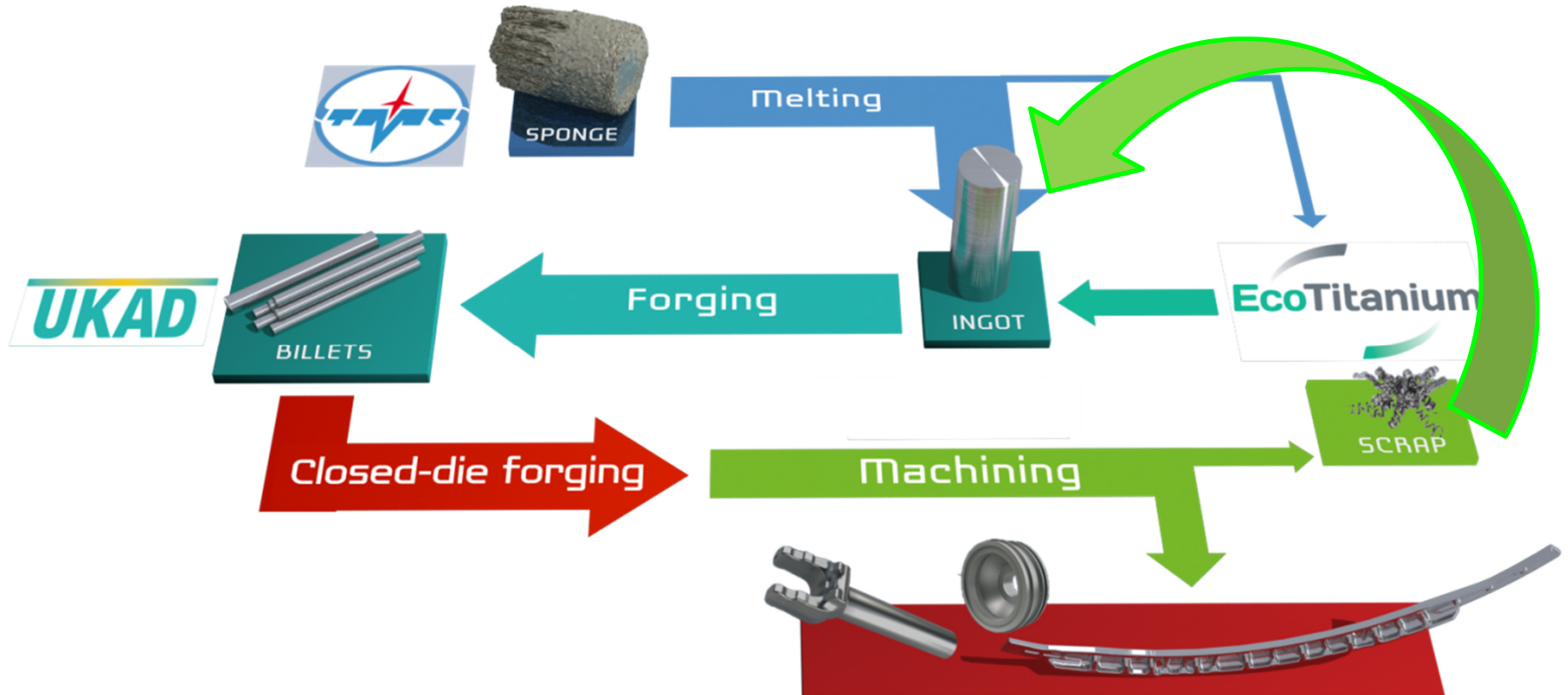

EcoTitanium reserves a large part of its capacity for all forgers, in the concept of circular economy.

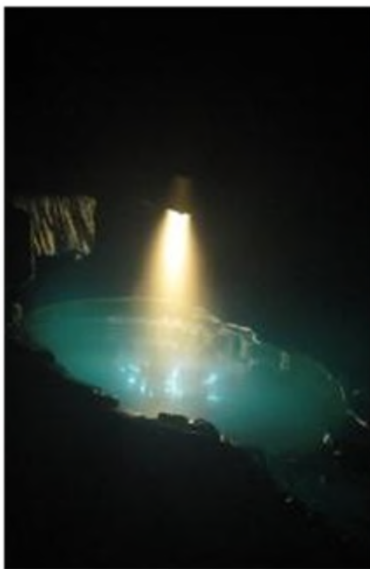

Thank you for your attention

