

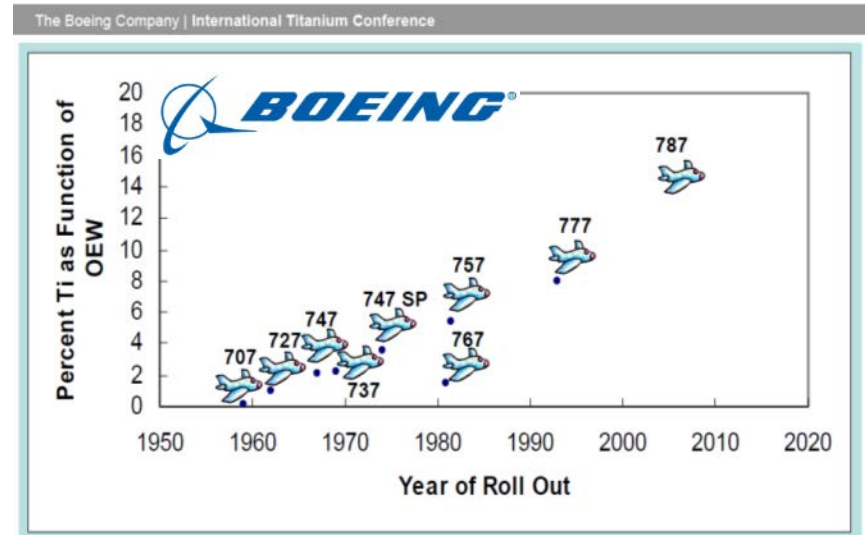

**Sep 2016**

The creation of **UKAD** was allowed by :

- the increase of Ti material in airplane structures

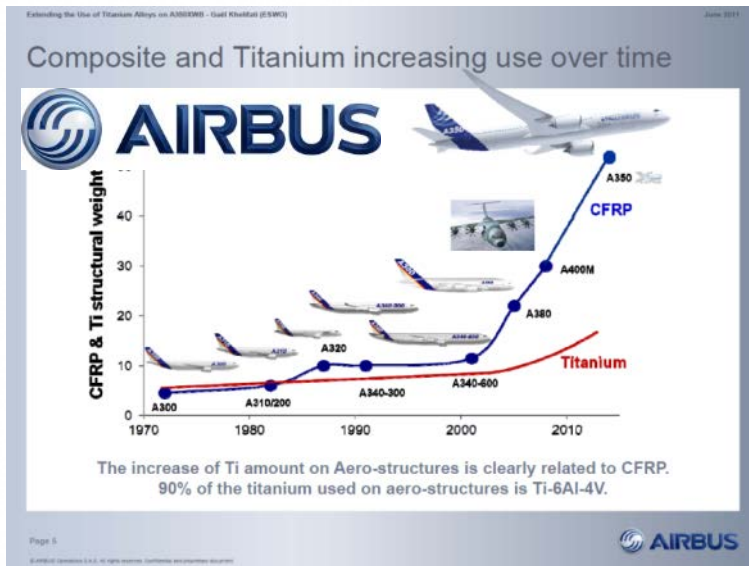

The creation of **UKAD** was allowed by :

- the increase of Ti material in airplane structures
- the **UKTMP** strategy with Ti downstream development
- the **Aubert et Duval** strategy with Ti upstream development
- the **Airbus** support with a 10 years sales agreement
- the french local authorities support

# UKAD

## UKAD

is a joint-venture which combines, in the titanium market, the forces of 2 companies :

➤ **Aubert & Duval**



➤ **UKTMP**



UKTMP is a Kazakh registered company. Well known for its high level of Titanium sponge quality :

1. Ilmenite mining operation
2. Titanium slag production
3. Titanium tetrachloride and magnesium production
4. Titanium sponge production
5. Titanium melting facility





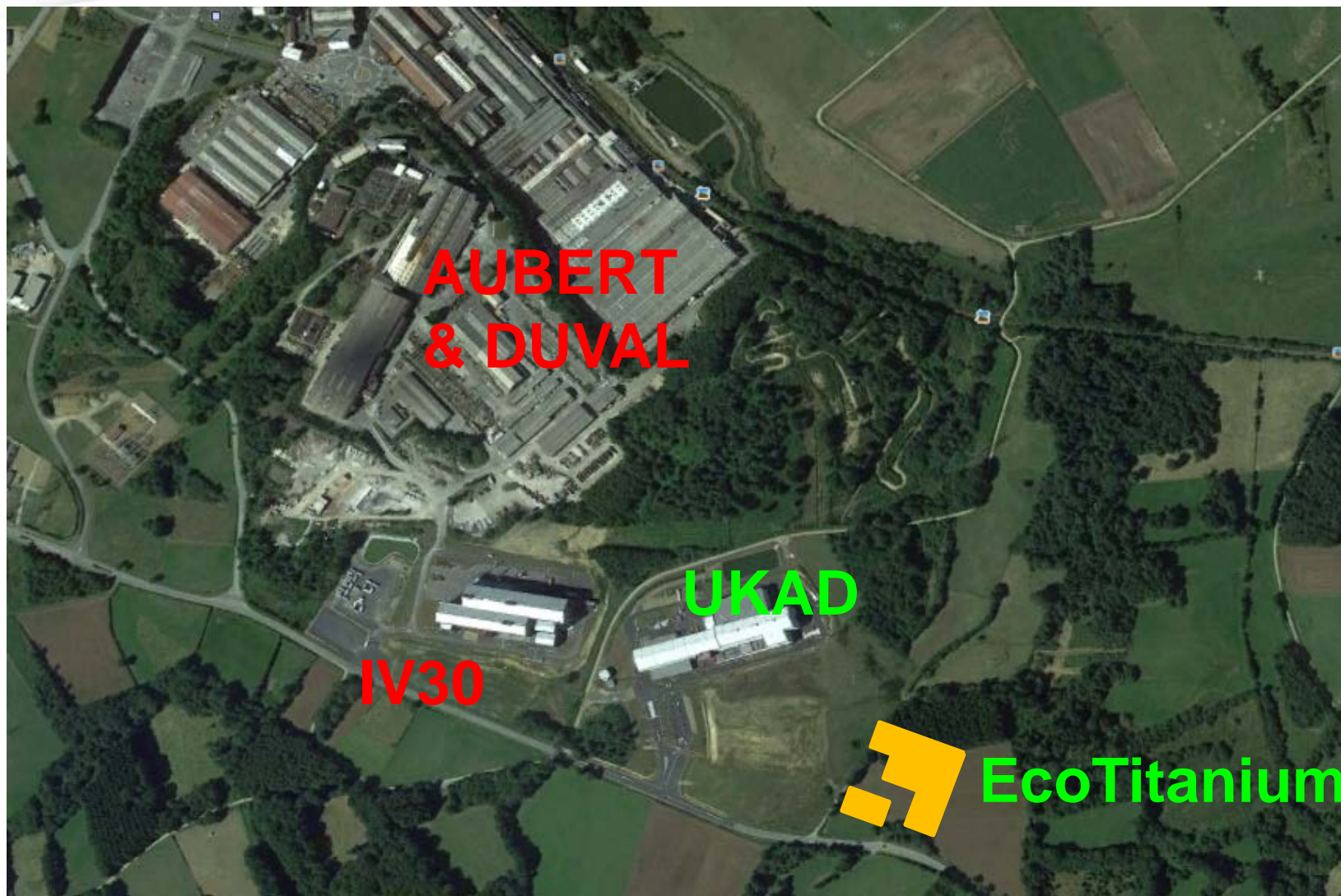

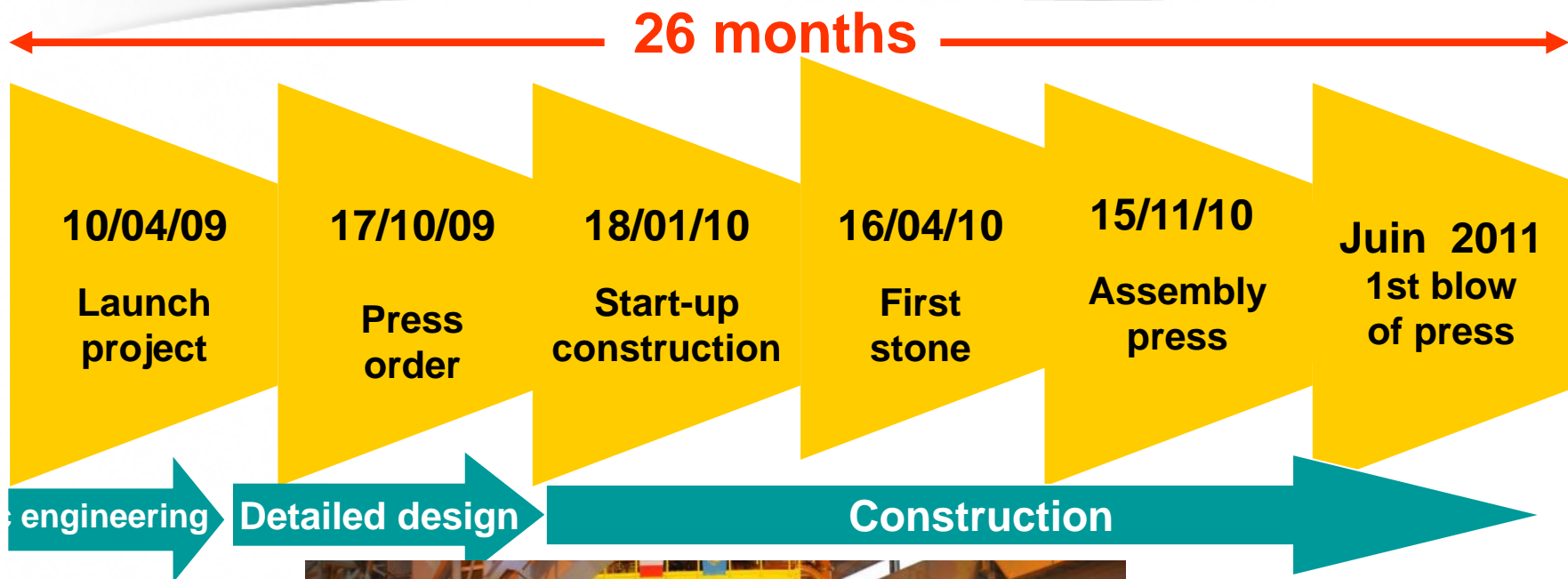

September 2011  
Inauguration

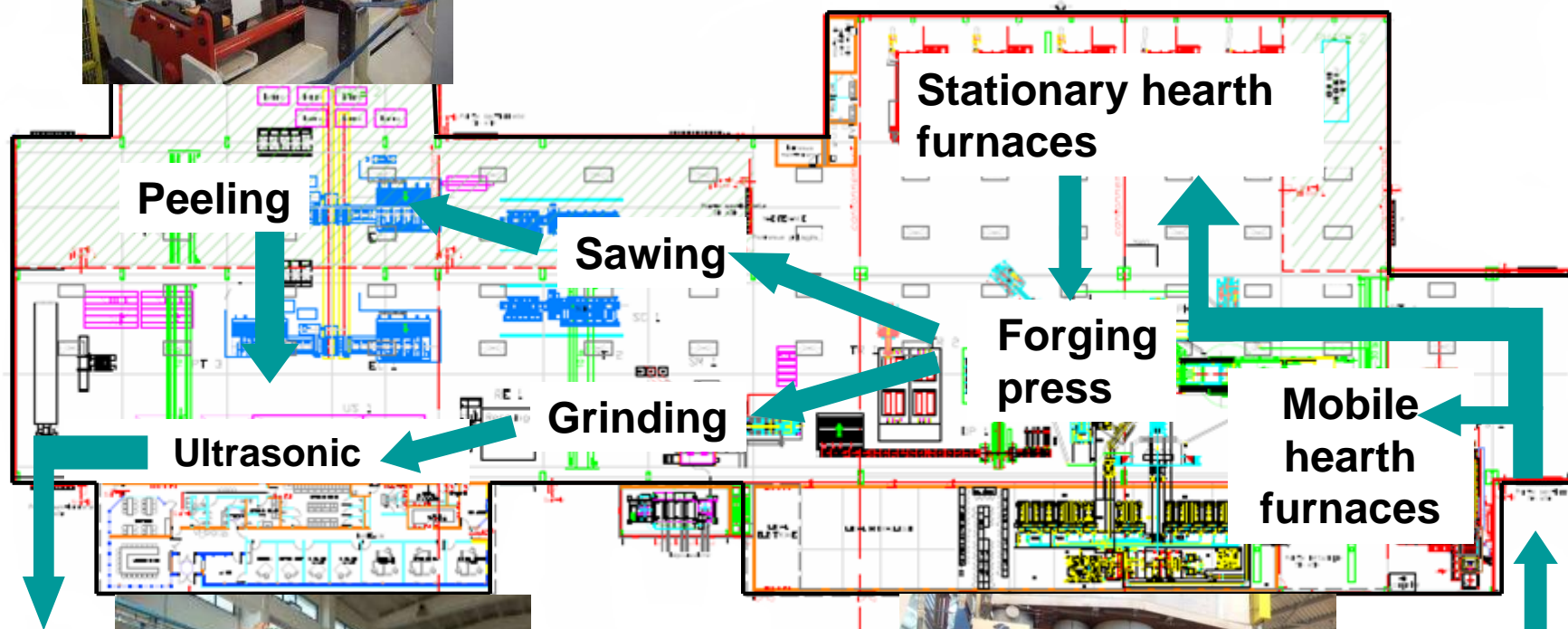

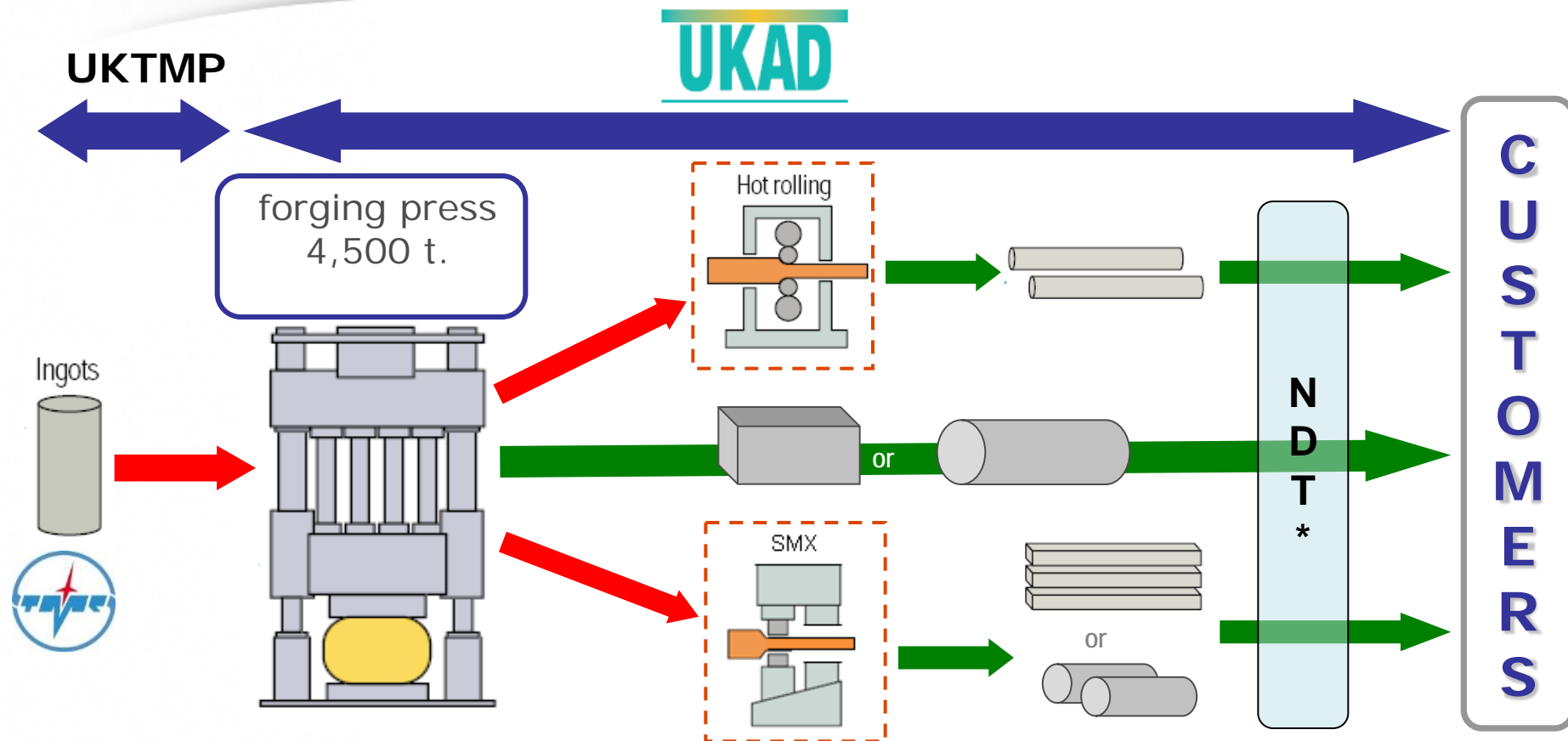

### → UKAD :

- Ingots from 7 (titanium) to 18 t
- Blooms and billets from 85 to 450 mm in Ø and 4 to 6 m long
- Bars from 55 to 85 mm

\*Non destructive tests (automatic multi-element ultrasonic)

Operations subcontracted to Aubert & Duval



## UKTMP



Ti Alloy Ingot

Many other forgers in Europe (3), UK (1) and USA (3).

## UKAD

### Billets



## CUSTOMERS

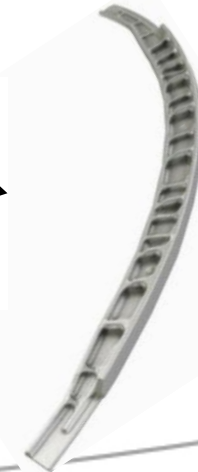

### UKTMP



Ti CP or Ti Alloy Ingot

### UKAD

Ingot → Blooms, Billettes



### CUSTOMERS

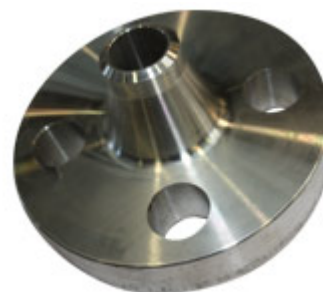

Welding Neck



Covers and flanges



UKTMP



Ti Alloy Ingot

# UKAD

Ingot → Blooms → Bars

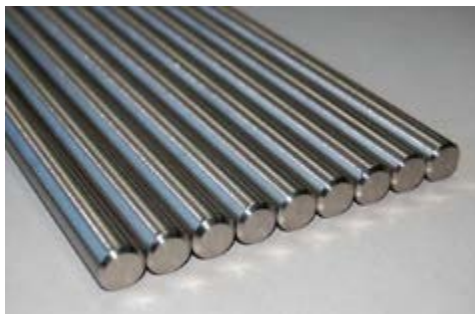

## CUSTOMERS

**Aeronautical  
fastening market**

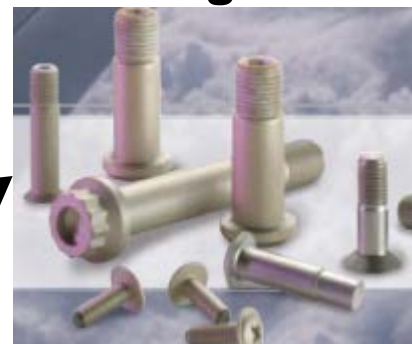

**Orthopedic  
Implants**



**Knee**



**Hip**

### UKAD Deliveries

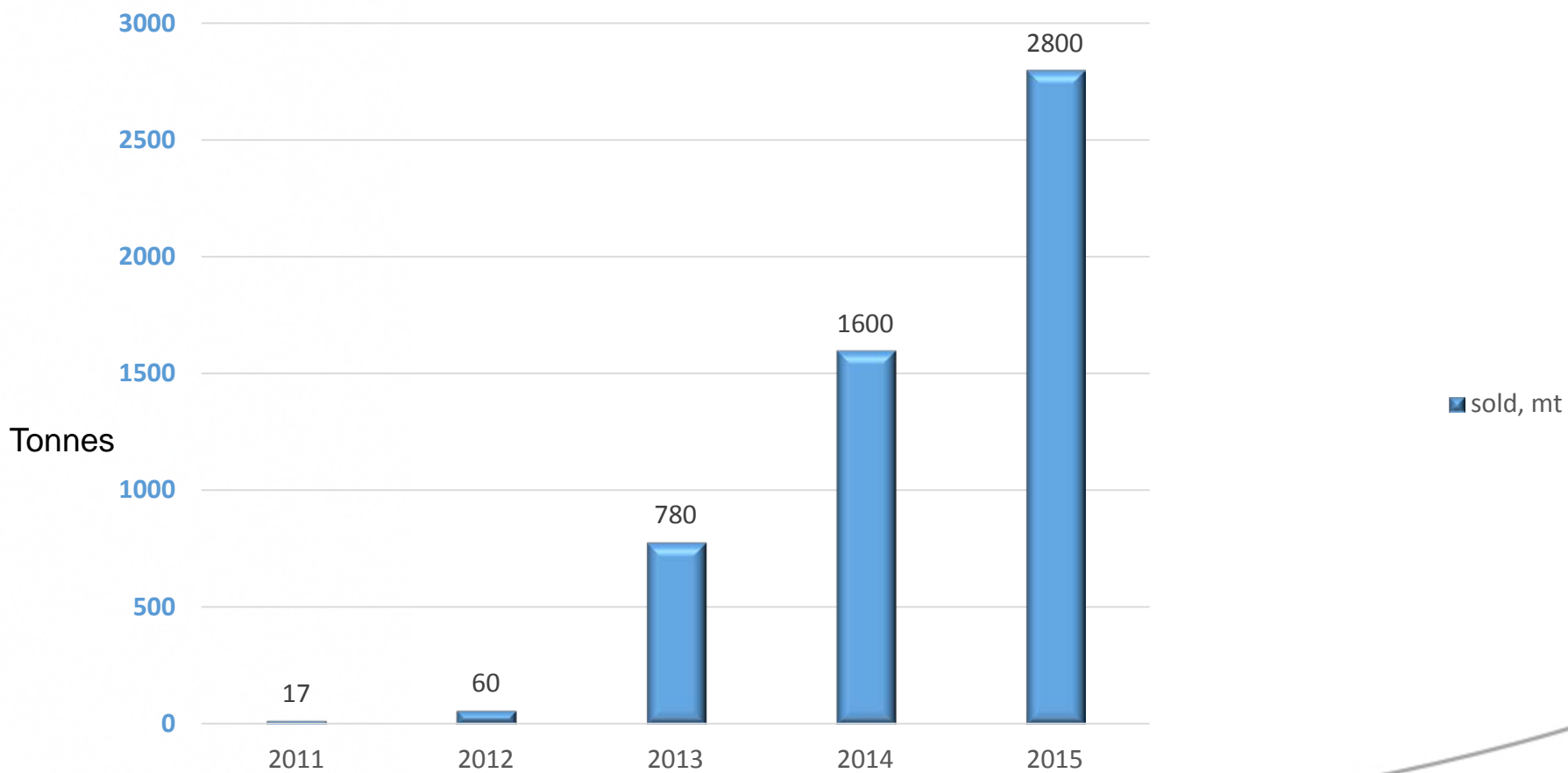

- ISO 9001 and AS 9100, last approval Dec 2015
- ISO 14 001 and OHSAS 18001, last approval Dec 2015
- Ultra Sonic Nadcap Certification in Dec 2014, confirmed in Nov 2015.
- **Airbus** :
  - IPCA Janv 2013 « C » → IPCA+ 28 Janvier 2016 « B »
- **Boeing** :
  - UKTMP has been formally qualified in August 2015.
- **UKAD** delivers billets and bars in accordance with **AMS 4928** and Ultra Sonic tested in accordance with **AMS 2631**.

# UKAD

## UKAD :

For the second year UKAD was awarded by Airbus :

Best Improver Award 2015 .

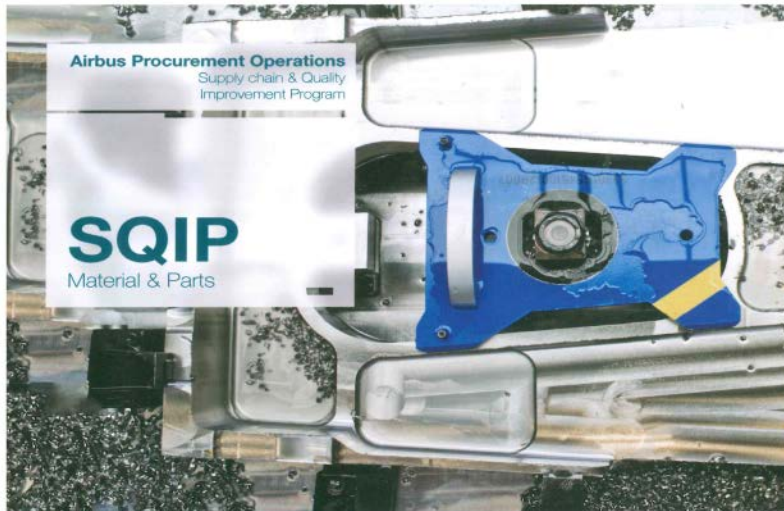

**Best Improver Award**

### UKAD

For demonstrated improvement of performance in 2015,  
Strong continuous improvement and customer-oriented approach,  
In line with Airbus targets and expectations.

**Klaus RICHTER**  
Chief Procurement  
Officer AIRBUS Group  
& AIRBUS

**Olivier CAUQUIL**  
Senior VP,  
Head of Material and  
Parts Procurement  
Chairman of the Airbus  
Group Material board

**Thomas MOIK**  
Senior VP,  
Head of Procurement  
Operations

**Thierry VUILLEQUEZ**  
VP Supply  
Chain & Quality  
Procurement Operations  
Material & Parts



# Partnerships form an integrated Titanium Solution

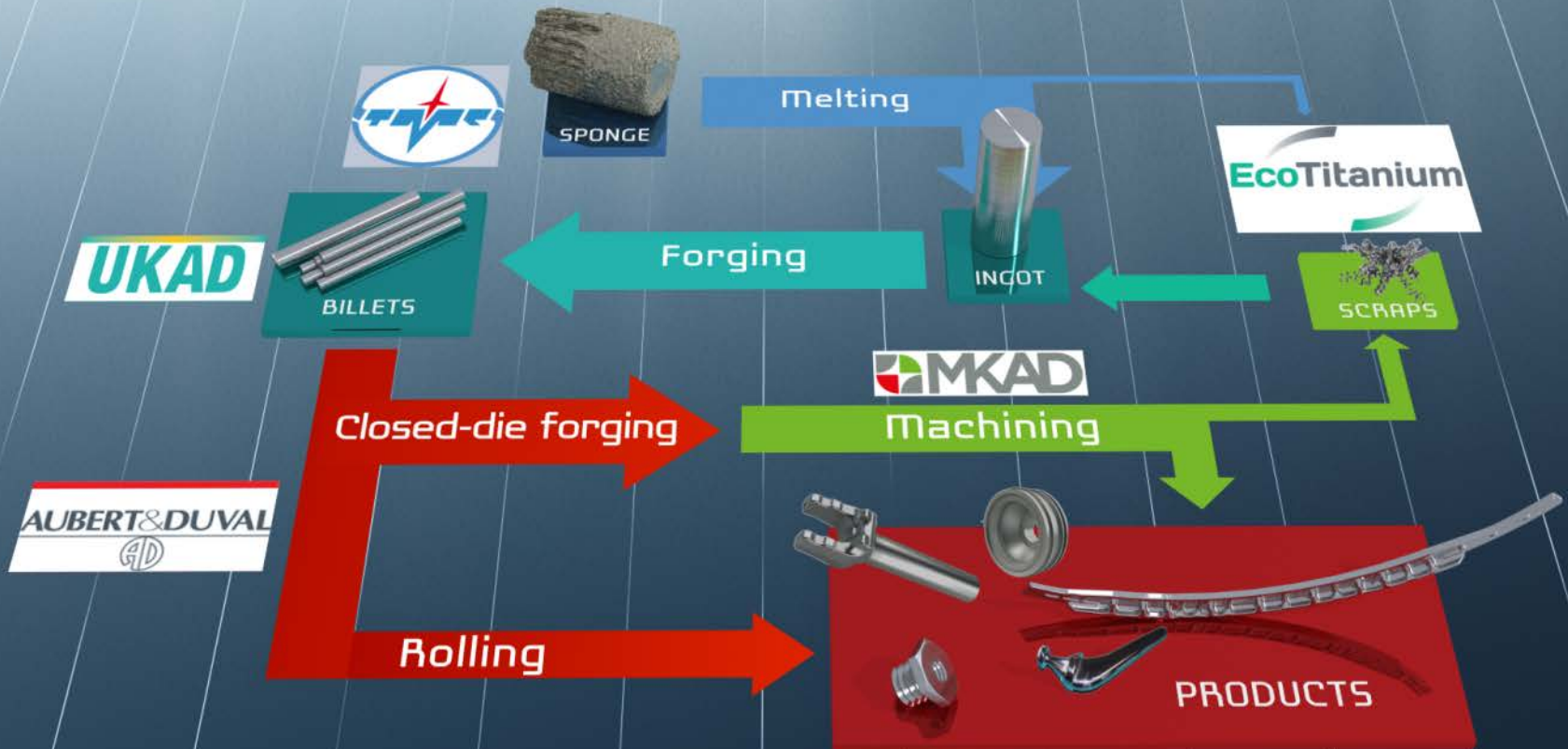

**A FULLY INTEGRATED SOLUTION FOR TITANIUM**

# Production generates significant volume of scrap

Titanium closed die parts generate huge volume of scrap

**Billet 200kg**



**Closed Die Part 150kg**



**Finished Part 20kg**



**Ratio Buy to Fly : 10**

# Scrap generated in Europe is a key for competitiveness of US titanium melters

European titanium scrap is mainly exported to USA : 9 500 tons in 2014

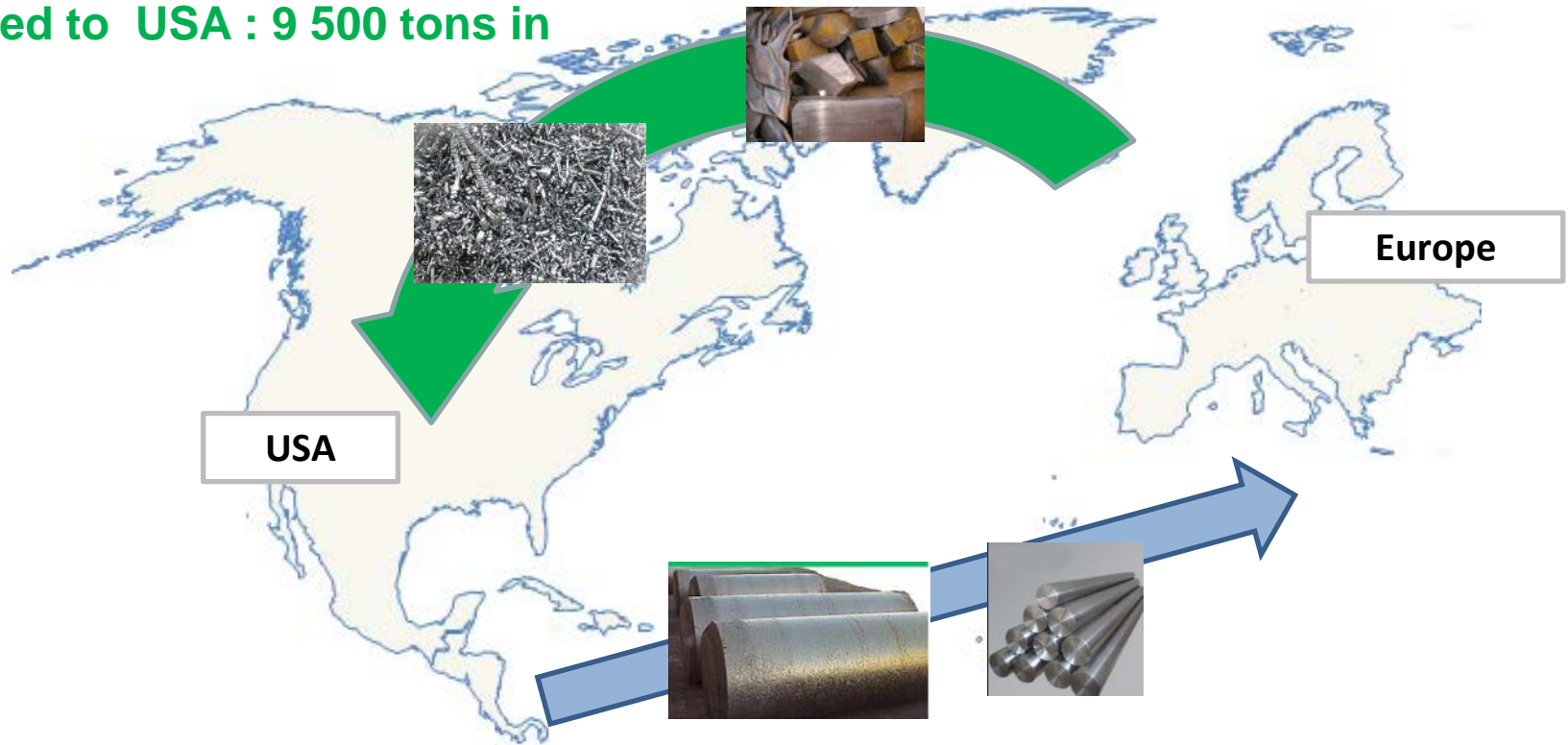

US ingots were mainly produced from titanium scrap in 2014, 63 % of the total consumption Scrap + Sponge.

# Committed shareholders

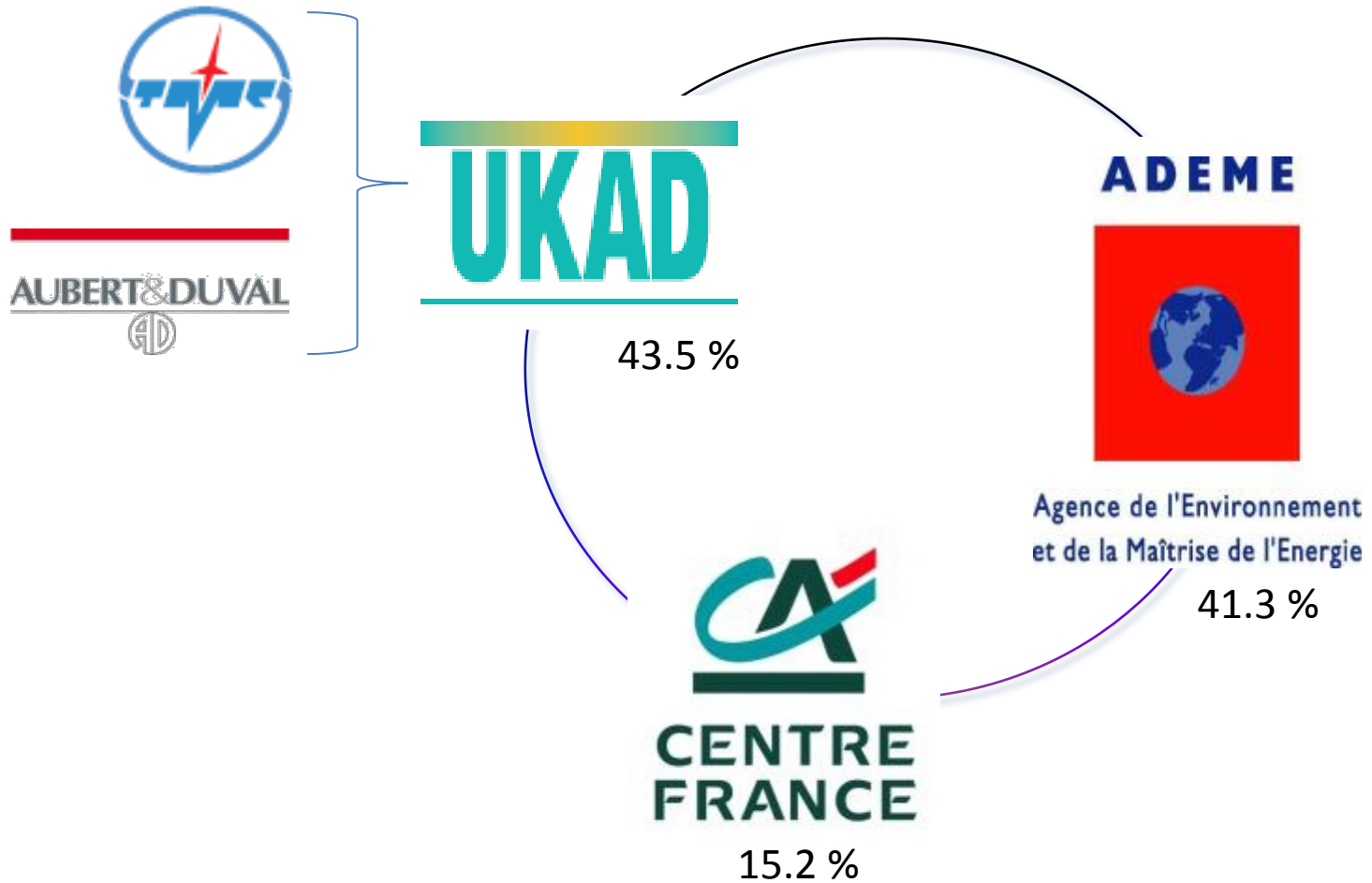

# Main Equipment : A Plasma Furnace Cold Hearth Refining

Loading system for turnings briquets

Loadind system for solids

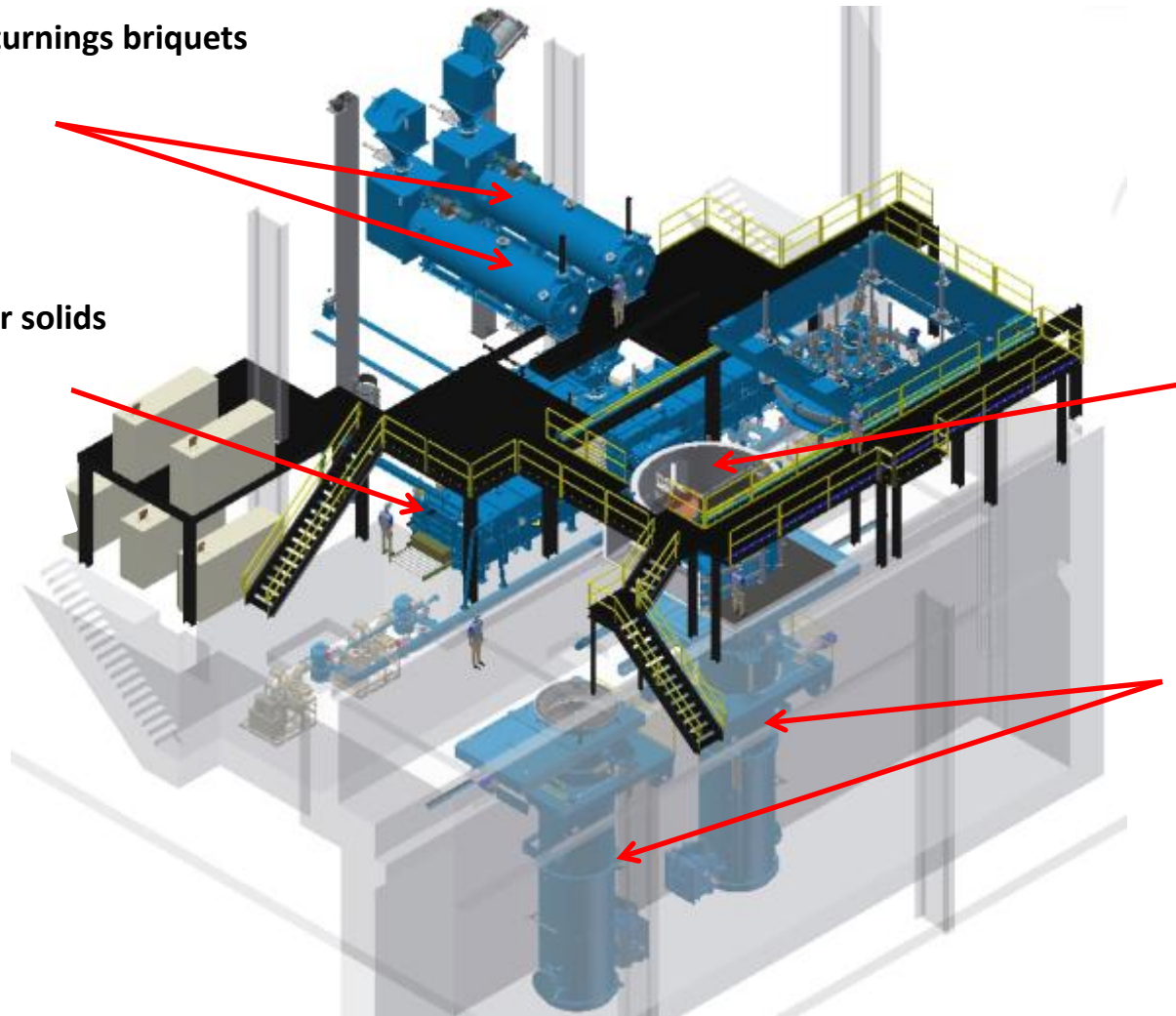

Melting Chamber

Electrods erection chamber

# Principle

Principle of a PAMCHR furnace.

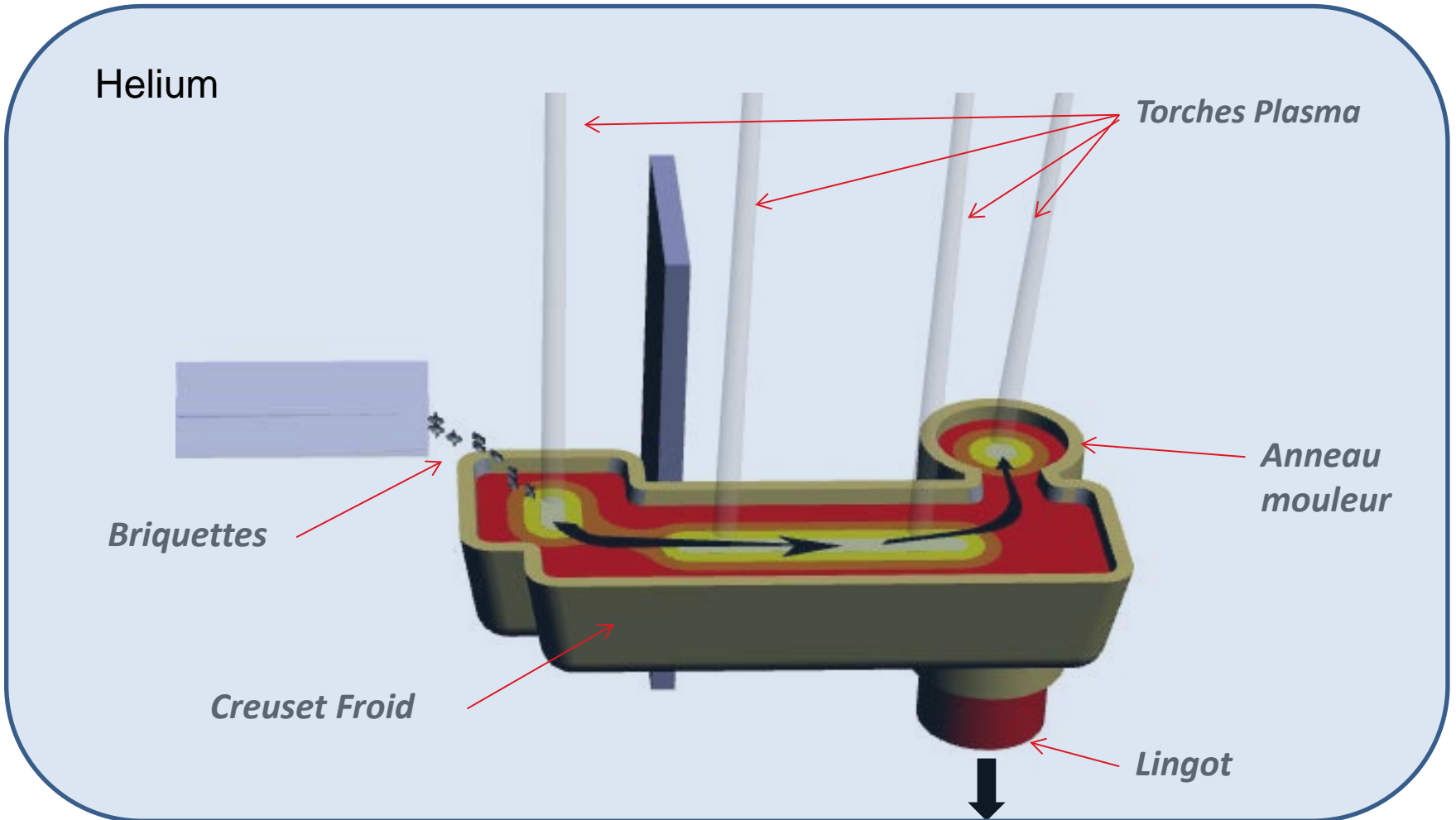

Melting 1700 °C

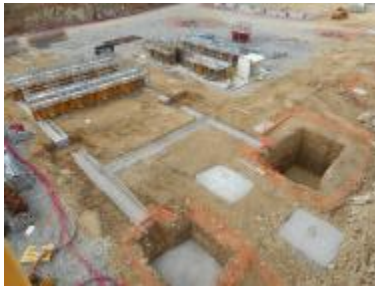

2010  
Reflection and  
project structuring

2015  
Erection of the new  
plant next to UKAD

2017  
Production startup

2022  
Full maturity

First deliveries with Ingots according  
AMS 4928: November 2017



EcoTitanium planning

# An open Solution for all UKAD customers

The revert loop will be available for all UKAD's customers, based on circular Economy.

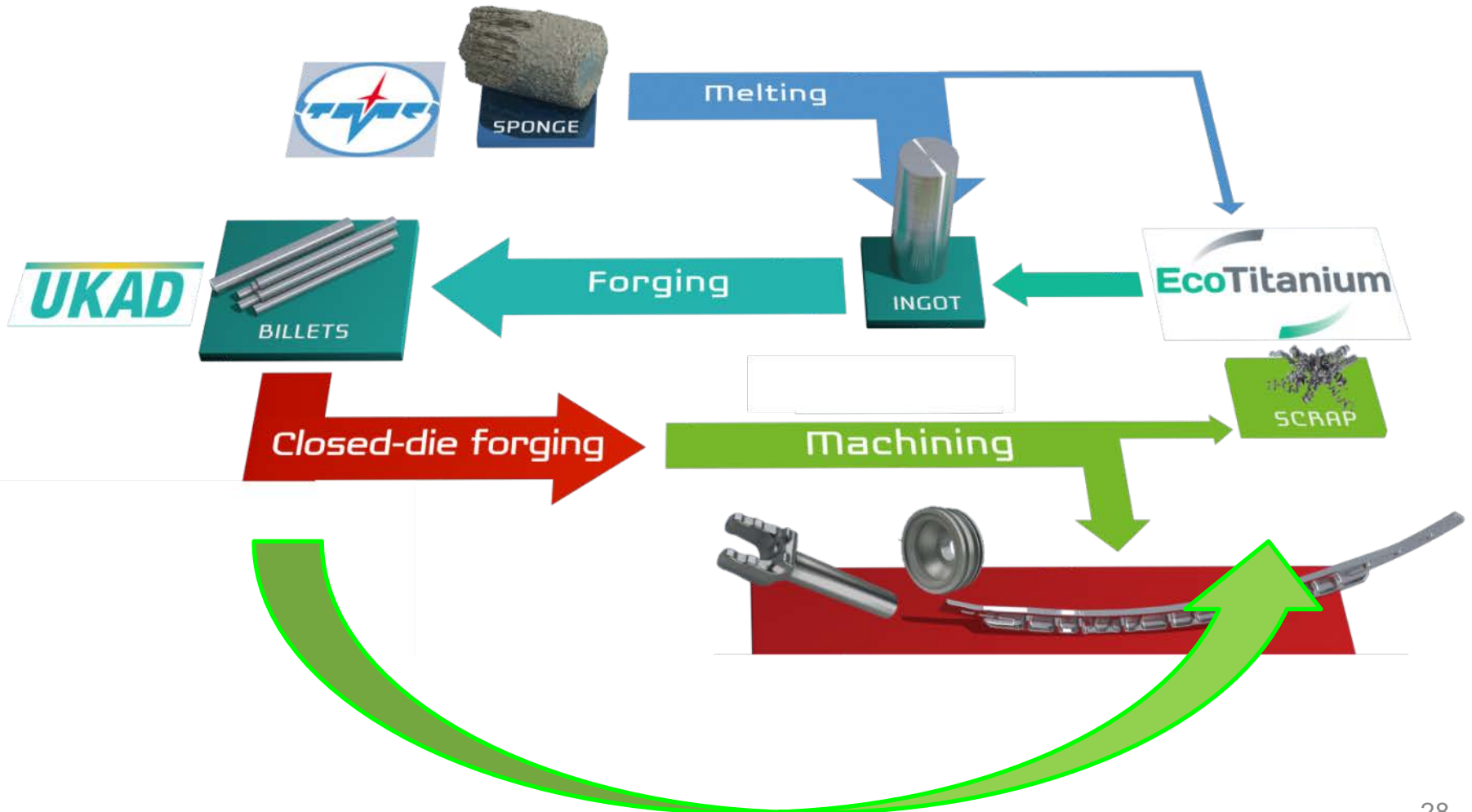



**Thank you for your attention**

